

PHONE NUMBER

+90 212 500 06 44

FAX

+90 212 500 06 46

EMAIL

info@ozgroupLtd.com.tr

WEB

ozgroupLtd.com.tr

ADDRESS

Fatih Sanayi Sitesi
İncirtepe Mah. Doğan Araslı Bulvarı 203 Sok.
E Blok No: 72/2 Zemin Kat
Esenyurt - İstanbul - Türkiye



ozmetal.com



ozgroupLtd.com.tr

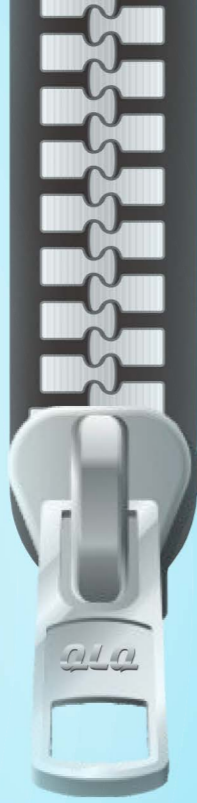

OZGROUP

Zipper Machines & Accessories





OZ GROUP Future Solutions Today

Oz Group Companies, whose core has been formed by our leading company in Turkey in the production of copper and copper alloy wire and strip for many years, has been operating in a wide range of foreign trade products for more than ten years.

Our group company has been one of the leading companies in the Turkish metal sector with copper and copper alloy products since 1987. Since this date, we have been responding to the demands of the manufacturers by following the new technologies in line with the demands of the manufacturers. Our group company produces strip and flat wire from metal, copper, brass and nickel alloys. In 2010, Y wire production, which broke new ground in zipper production, started. Zipper teeth machines required for Y wire are also supplied by our company. As our group company, it serves metal zipper, metal button, electricity, electronics, bathroom armature, automotive, automation and decoration sectors. We also export the same products abroad.

In addition to our export activities, we continue our import activities with our professional network and commercial connections in Far East countries, especially in China, where our company is located. As Oz Group Companies, we meet your needs for all kinds of special machinery, equipment, raw materials and intermediates required not only for standard products, but also for improving your business and production quality and increasing your exports, which are a requirement of the global competitive environment, with tomorrow's modern technological standards, superior service quality and reasonable prices. we supply.



IMPORT & EXPORT Expert Consulting Support

In the globalizing world, the basic condition of being able to survive in the international global competition environment and to produce fast solutions to market demands is to have strong competitive dynamics. This is through production in accordance with documented quality standards, focusing on innovations, innovation and R&D studies. In this context, we offer the most optimum solutions to our customers with our expert consultant staff so that they can benefit from all government supports and incentives that they can benefit from in the current system at every stage they need.



WITH 35 YEARS OF EXPERIENCE Market Information and Special Production

Whatever your need, with our knowledge of the market and dominance of the market, we provide quality and suitable products with our professional network spread all over China. Not only for standard products, but if you need a special product, we make the necessary connections so that it can be produced in the right place under the most suitable conditions. We are based on customer satisfaction in the preparation of prototypes of products, quality control and determination of the best prices and lead times. With our company established in China and our extensive commercial network, we reach all parts of China and overcome all formalities.

CONTENTS



1 /P01
—
Pressing Machine & Related Device

2 /P02
—
Pressing Mould

3 /P03
—
Hot Chamber Die Casting Machine & Spare Part

4 /P04-P06
—
Zinc Die Casting Mould, Spare Part & Sample

5 /P07
—
Plastic Injection Machine

6 /P07-P08
—
Plastic Injection Mould, Spare Part & Sample

7 /P08-P10
—
Plastic Zipper Injection Mould & Spare Part

8 /P10
—
Hole Punching Mould for Zipper

9 /P11-P12
—
Polishing Machine & Material

10 /P13-P14
—
Painting & Plating Related Machine & Device

11 /P15-P19
—
Slider Assembly Machine

12 /P20-P25
—
Long-chain Zipper Manufacturing Machine

13 /P26-P39
—
Finished Zipper Manufacturing Machine

14 /P40-P42
—
Spare Part of Zipper Manufacturing Machine

15 /P43
—
Silicone Product Manufacturing Machine

16 /P43
—
PVC Product Manufacturing Machine

17 /P44
—
Various Moulds Related Machines & Tools

18 /P45
—
Various Button Manufacturing Machines & Material

19 /P46
—
Various Bag Accessories Manufacturing Machines

20 /P47
—
Zipper, Slider & Hardware Test Machine

21 /P48
—
Jacquard Machine and Crochet Machine

22 /P49
—
Hook& Loop/ Velcro Manufacturing Machines

23 /P50
—
Centrifugal Die Casting Series Manufacturing Machines & Raw Materials

24 /P51-P53
—
Raw Material & Accessory for Zipper & Slider

25 /P54-P55
—
Wire/Strip for Zipper & Slider

26 /P56-P59
—
Slider & Pin Box

27 /P60
—
Zipper Tape

28 /P60
—
Long-chain Zipper

29 /P61
—
Finished Zipper

30 /P61-P62
—
Button Part

31 /P63-P65
—
Bag Accessories

32 /P65
—
Velcro (hook & loop)

33 /P66
—
Chemical for Plating

1 Pressing Machine & Related Device



QLQ-NPM10/QLQ-NPM16
Automatic Pressing Machine (10T/16T)



QLQ-NPM25
Automatic Pressing Machine (25T)



QLQ-NPM80
Automatic Pressing Machine (80T)



QLQ-HPM20
Automatic Pressing Machine (20T, high speed)



QLQ-HPM30
Automatic Pressing Machine (30T, high speed)



QLQ-APM16 / QLQ-APM25
Automatic Pressing Machine (16T, 25T,
pneumatic model, this model should work with
air compressor)



Material Feeding Device
(roller system, maximum wire thickness: 1.6mm,
width: 100mm, distance for sending material:
50mm)



Material Feeding Device
(numerical control type)



Wire Frame
(vertical system without transducer and
electronic ruler, wire maximum weight:
200kg)



Wire Frame
(horizontal system with transducer and
electronic ruler)



QLQ-WWCM
Automatic Waste Wire Crushing Machine



Drop Oiler (for cooling wire)

2 Pressing Mould

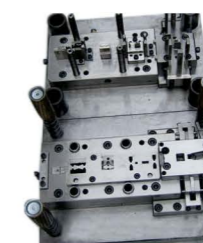
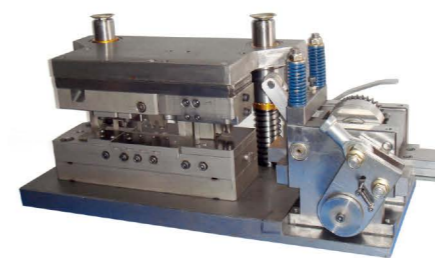

old type

new type

YG Slider Body Mould



YG Slider Spring Mould

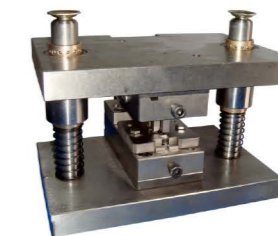

YG Slider Puller Mould

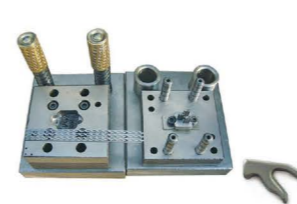

Slider Needle/Monkey Mould
(Y shape, 3 cavities)



Slider Needle/Monkey Mould
Spare Part (Y shape, 3 cavities)



Slider Needle/Monkey Mould
(Y shape, 5 cavities)



Slider Needle/Monkey Mould
Spare Part (Y shape, 5 cavities)

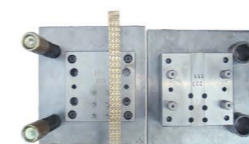

Slider Needle/Monkey Mould (C shape, 6 cavities)



Slider Spring Mould (for 3 components auto-lock slider)



Hook Mould



Flat/Middle Puller Mould

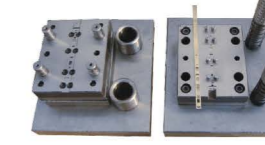

Pressing Puller Mould

3 Hot Chamber Die Casting Machine & Spare Part

3.1 Automatic Hot Chamber Die Casting Machine



QLQ-HDCM-15T
Automatic Hot Chamber Die Casting Machine (15T)



QLQ-HDCM-25T
Automatic Hot Chamber Die Casting Machine (25T)



QLQ-HDCM-30T
Automatic Hot Chamber Die Casting Machine (30T)



QLQ-HDCM-40T
Automatic Hot Chamber Die Casting Machine (40T)



QLQ-HDCM-50T
Automatic Hot Chamber Die Casting Machine (50T)



QLQ-HDCM-68T
Automatic Hot Chamber Die Casting Machine (68T)



QLQ-LBSM
Automatic Barrel Separating Machine (lift type)



QLQ-USM
Automatic Ultrasonic Separating Machine



Automatic Zinc Material Feeding System

3.2 Spare Part of Automatic Hot Chamber Die Casting Machine



Zinc Melting Machine



Zinc Melting Pot (type 1)



Zinc Melting Pot (type 2)



Air Bag



Shooting Pole
(32mm, 35mm, 38mm)



Electric Heating Pipe



Heating Sheath



Material Cup



Material Entrance



Body of Nozzle



Head of Nozzle



Steel Ring/Piston Ring

4 Zinc Die Casting Mould, Spare Part & Sample

4.1 Zinc Die Casting Mould



Auto-lock Slider Cap Mould

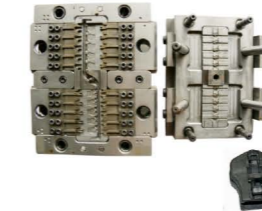

M51A Auto-lock Slider Body Mould



N51A Auto-lock Slider Body Mould

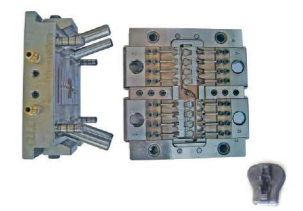

D51A Auto-lock Slider Body Mould

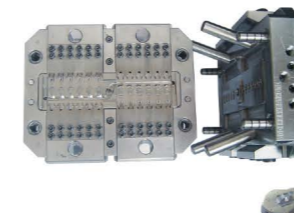

N53 Pin-lock Slider Body Mould

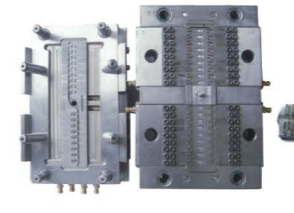

N31A Spring-lock Slider Body Mould

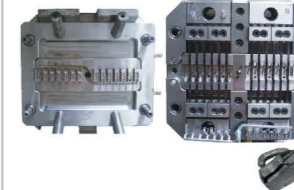

N36 Non-lock Slider Body Mould

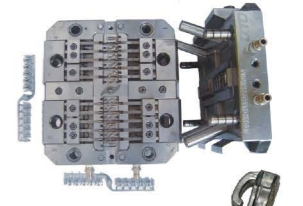

N56 Non-lock Reverse Slider Body Mould

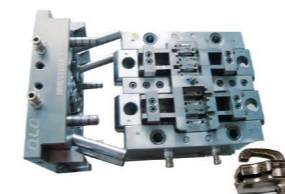

D104 Double Puller Non-lock
Slider Body Mould

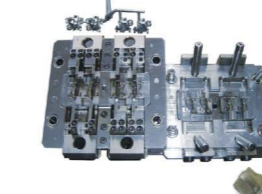

N106 Keyhole Non-lock
Slider Body Mould

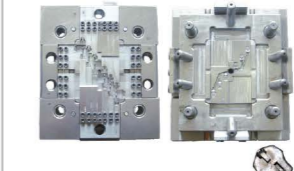

3# Italy Type Slider Body Mould

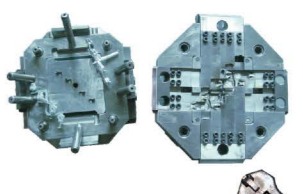

5# Italy Type Slider Body Mould

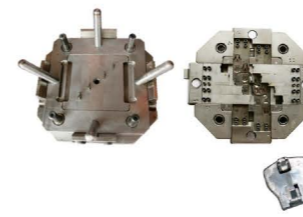

8# Italy Type Slider Body Mould

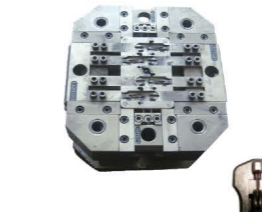

Brass Cap Slider Body Mould

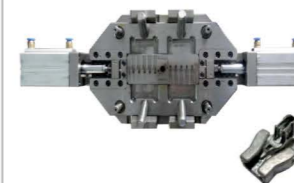

Invisible Slider Body Mould



Puller Mould

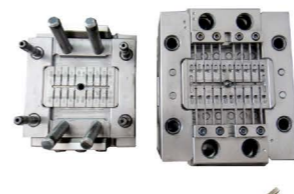

Pin Pin Mould



Pin Mould



Box Mould



Zinc H Bottom Stop Mould

4.2 Spare Part of Zinc Die Casting Mould



Puller Mould Insert



Puller Mould Insert



Puller Mould Insert



Pin & Box Mould Insert

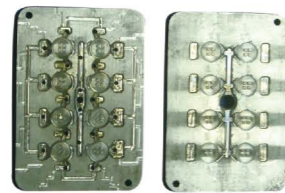

Button Mould Insert

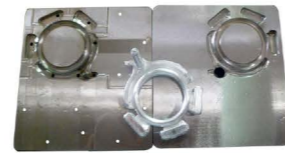

Ring Mould Insert



Mould Insert of Car Spare Part



Fixed Logo Bottom Mould Insert of Auto-lock Slider



Fixed Logo Bottom Mould Insert of Italy Type Slider



Flexible Small Logo Part



N56 Non-lock Slider Body Mould Moving Core



Invisible Slider Body Mould Moving Core



Auto-lock Slider Body Mould Window Core



Italy Type Slider Body Mould Window Core

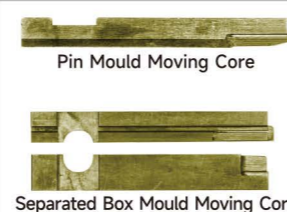

Pin Mould Moving Core

Separated Box Mould Moving Core



Integral Box Mould Moving Core



Italy Type Slider Body Mould Moving Core



N106K Non-lock Slider Body Mould Moving Core



N71A Auto-lock Slider Body Mould Moving Core



Brass Nozzle

4.3 Zinc Die Casting Mould Sample

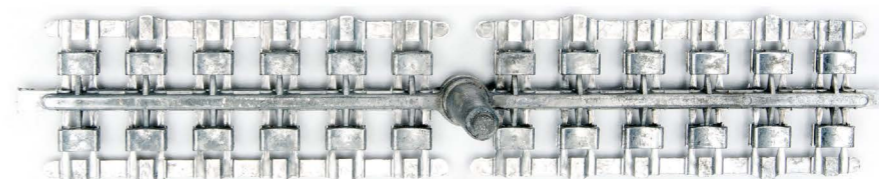
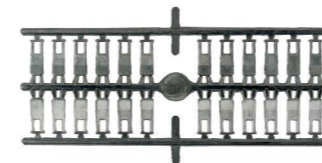

5 Plastic Injection Machine



6 Plastic Injection Mould, Spare Part & Sample

6.1 Plastic Injection Mould

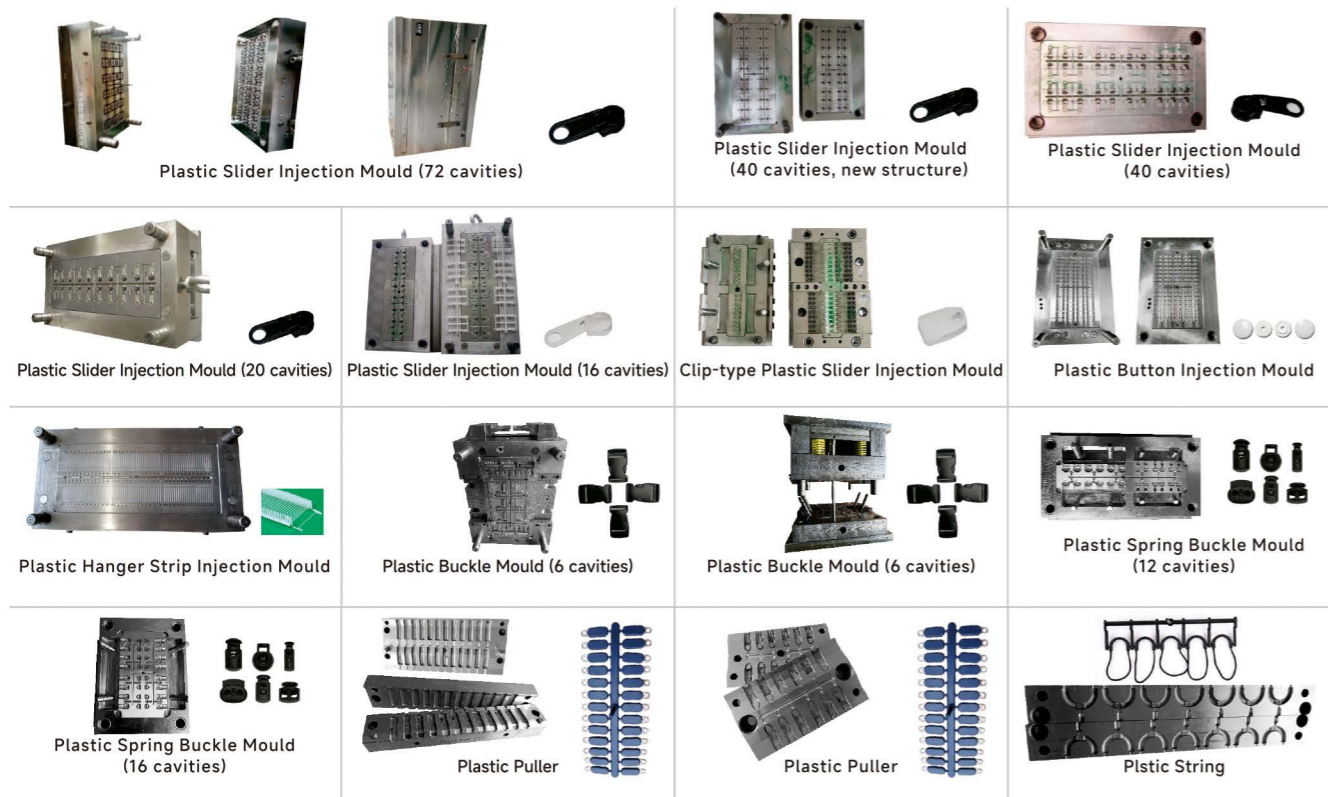

6.2 Spare Part of Plastic Injection Mould



6.3 Plastic Injection Mould Sample



7 Plastic Zipper Injection Mould & Spare Part

7.1 Plastic Zipper Teeth Injection Mould QLQ-DTIM

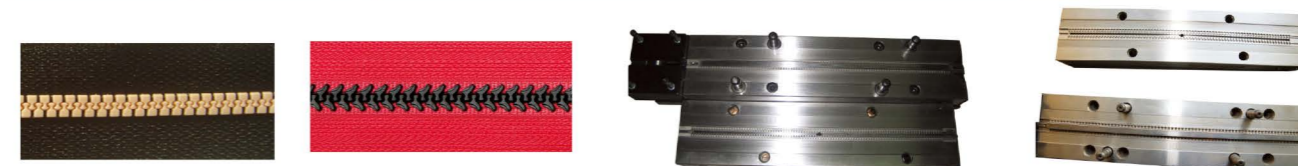

7.2 Plastic Zipper Teeth with Bottom & Top Stop Injection Mould QLQ-DTBTM

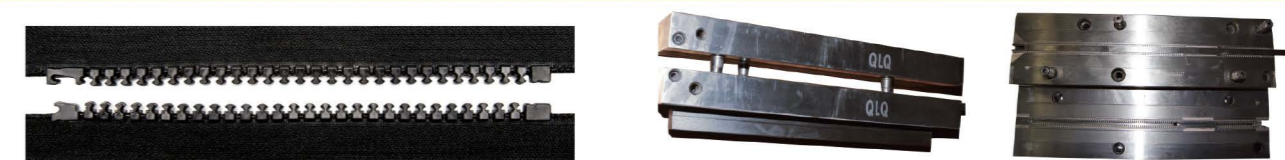

7.3 Plastic Zipper Pin Box with Top Stop Injection Mould QLQ-DPBTM



7.4 Plastic Zipper Pin Pin With Top Stop Injection Mould QLQ-DPPTM



7.5 Plastic Zipper Bottom Stop with Top Stop Injection Mould QLQ-DBTM



7.6 Nylon Zipper Pin Box with Top Stop Injection Mould QLQ-NPBTM



7.7 Nylon Zipper Pin Pin with Top Stop Injection Mould QLQ-NPPTM

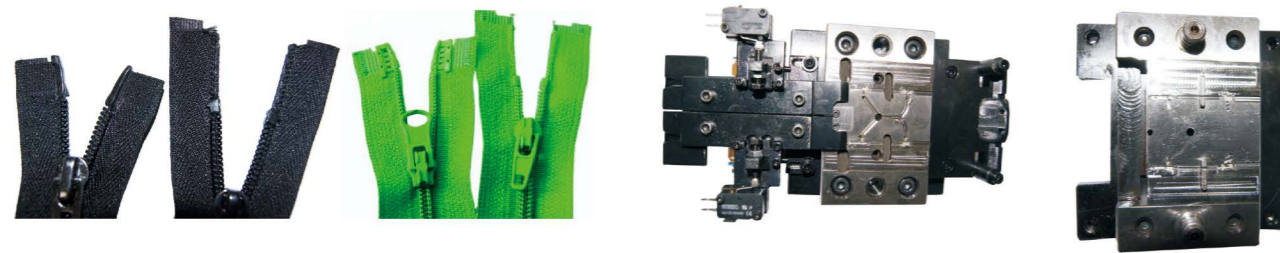

7.8 Nylon Zipper Bottom Stop with Top Stop Injection Mould QLQ-NBTM

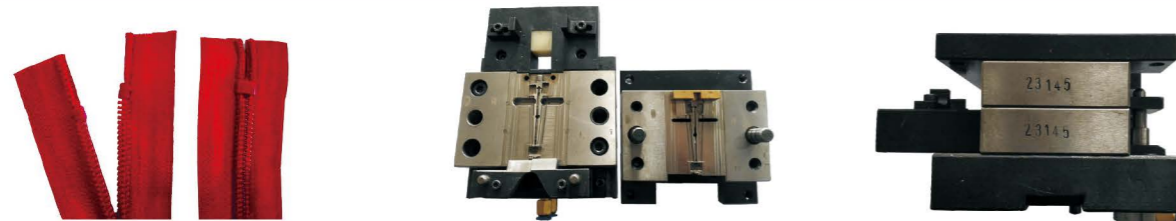

7.9 Other Type Injection Mould

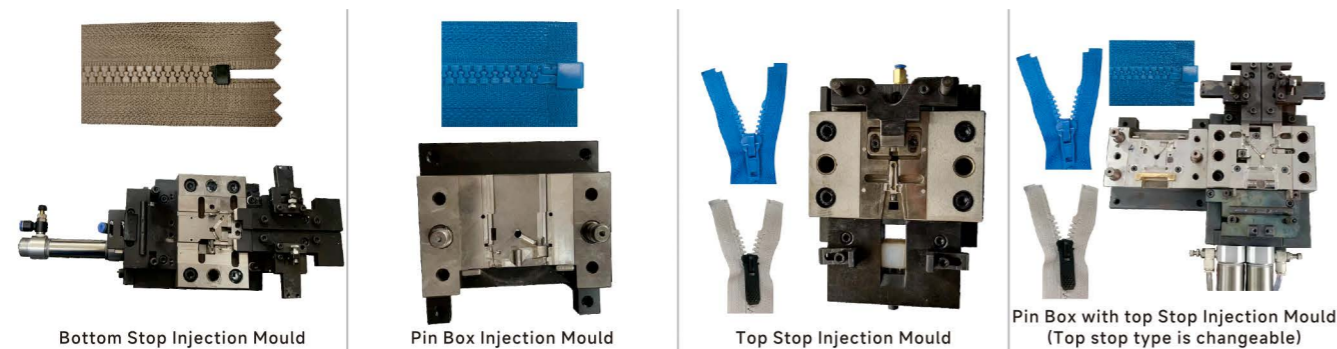

7.10 Spare Part of Injection Mould



8 Hole Punching Mould for Zipper



8.1 Hole Punching Mould for Nylon Open-end Zipper

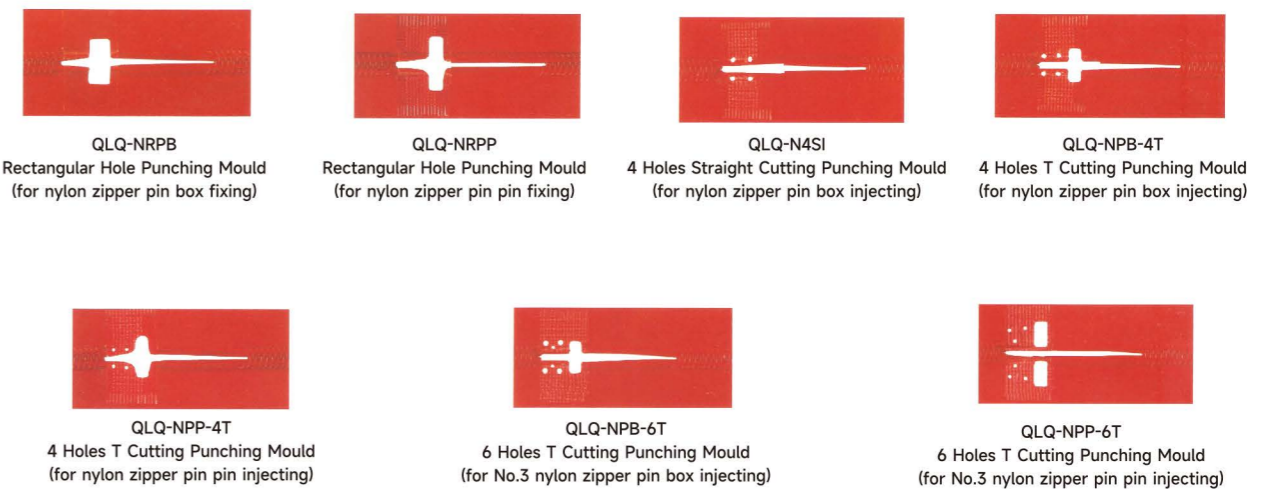

8.2 Hole Punching Mould for Metal Open-end Zipper

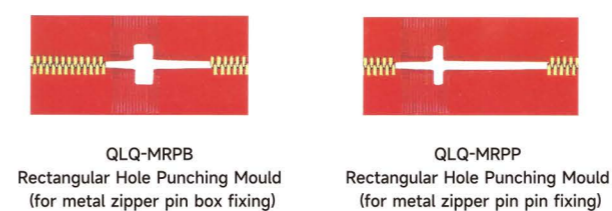

8.3 Hole Punching Mould for Plastic Open-end Zipper

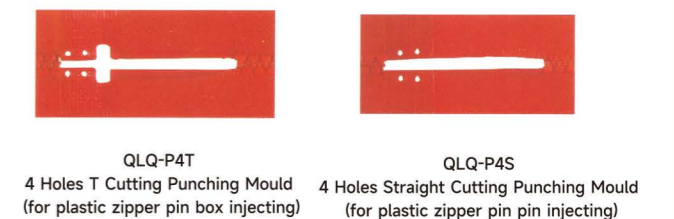

9 Polishing Machine & Material

(suitable for slider, puller, needle, hook, button & other hardware)

9.1 Polishing Machine



QLQ-SFSM
Hardware Product & Frame
Separating Machine



QLQ-PPFSM
Plastic Product & Frame
Separating Machine



QLQ-BTPM
Barrel Type Polishing Machine



QLQ-VTPM
Vibrating Type Polishing Machine



QLQ-WTPM
Whirlpool Type Polishing Machine



QLQ-CTPM
Centrifugal Type Polishing Machine



QLQ-OMPM
Open Mouth Polishing Machine

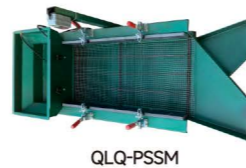

QLQ-PSSM
Product & Polishing Stone
Separating Machine

9.2 Polishing Material



Round Shape Rough
Polishing Stone



Triangle Shape Rough
Polishing Stone



Derlin Coniform Shape
Fine Polishing Stone



White Aluminum Round Refined
Polishing Ball /Painting Stone



Porcelain Refined Polishing Stone



Aluminum and Porcelain Oblique and
Round Column Refined Polishing Stone



Tea Seed Powder



Anti-rust Powder



Oil Cleaning/Degreasing Powder



Oil Cleaning/Degreasing Agent



Brightener/Shiny Agent

9.3 Polishing Machine & Material



QLQ-ADPM
Automatic Dry Type Polishing Machine



Polishing Liquid



Walnut Shell Polishing Material



Bamboo Grain Polishing Material

9.4 Hand Polishing Machine & Material



QLQ-HPM-1
Hardware Polishing/Buffering Machine



QLQ-HPM-2
Hardware Polishing/Buffering Machine



Manual Sander Machine
(complete hand polishing)



Polishing Machine
Dust Cover



Slider Insert-to-Clamp Machine

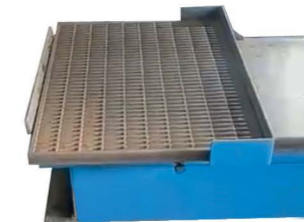

Manual
Hardware Arranging Machine



Dog Hook Clamp

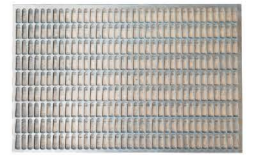

Clamp



Linen Polishing Wheel
(rough polishing or fine polishing)



Fabric Polishing Wheel
(refined polishing)



Cotton Polishing Wheel
(refined polishing)



Bleached Fabric Polishing Wheel
(refined polishing)



Linen Polishing Wheel (set)



Denim Fabric Polishing Wheel
(set)



Yellow Wax (rough polishing)



Purple Wax (fine polishing)



Green Wax (refined polishing)

10 Painting & Plating Related Machine & Device

(suitable for slider, puller, needle, hook, button & other hardware)

 QLQ-APM Automatic Phosphating Machine	 QLQ-SPM Automatic Barrel Painting Machine	 Stainless Steel Basket of Painting Machine	 Machine Painting Gun	 Hand Painting Gun
 Electrostatic Painting Gun	 Hand Painting Frame (type 1)	 Hand Painting Frame (type 2)	 QLQ-SAM Automatic Slider Arranging Machine	 QLQ-HPSC Hand Painting Case (manual painting)
 QLQ-HPM Automatic Hanging/Rack Painting Machine	 QLQ-BSDM Hot-wind Centrifugal Dryer(A)35kg (material: both inside and outside are stainless steel, bottom is cast-iron)	 QLQ-BSDM Hot-wind Centrifugal Dryer(B)35kg (material: inside is stainless steel, outside is iron, bottom is cast-iron)	 QLQ-OTM Small Oven Machine (for testing)	 QLQ-OVM Automatic Oven Machine (single door)
 QLQ-OVM Automatic Oven Machine (double doors, one side open)	 QLQ-OVM Automatic Oven Machine (double doors, two sides open)	 QLQ-BPM Barrel Plating Test Machine	 QLQ-BPM Small Barrel Plating Machine	 QLQ-BPM Barrel Plating Machine (single basket)
 QLQ-BPM Barrel Plating Machine(4 baskets)	 Washing Tank	 Automatic Washing Tank	 QLQ-UCM Ultrasonic Cleaning Machine	
 QLQ-TM Trichloroethylene Machine (for removing wax)	 Swing Head for Rack Plating Machine	 QLQ-RPMSH Rack/Hanging Plating Machine (single tank)	 QLQ-RPM Rack/Hanging Plating Machine (auto, semi-auto & manual available)	

 Row Type Hanger for Rack Plating	 Cage Type Hanger for Rack Plating	 Hardware before Rack Plating	 Hardware after Rack Plating
 Automatic Slider Hanging Machine	 Titanium Anode Basket	 Carbon Plate/Tin Plate	 Plating Heating Pipe
 QLQ-CR-1 Current Rectifier (200A-1000A)	 QLQ-CR-2 High Frequency Current Rectifier (200A-1000A)	 QLQ-CRF Corrosion-resistant Filter	 Filter Core
 QLQ-PCM Plating Cooling Machine	 QLQ-UCM Ultrasonic Cleaning Machine	 Laboratory PH Burette Device	
 Hull Cell	 Chemical Apron (acid and alkali resistant)	 Measuring Cup	 Chemical Gloves (acid and alkali resistant)

11 Slider Assembly Machine

11.1 Various Non-lock Slider Assembly Machine



QLQ-006

Automatic Slider Body De-burr/Broaching Machine (for 1 pc of slider body)



QLQ-061

Automatic Slider Body De-burr/Broaching Machine (for 2 pcs of slider bodies)



QLQ-062

Semi-automatic Non-lock Slider Assembly Machine



QLQ-002

Automatic Non-lock Slider Assembly Machine



QLQ-015A

Semi-automatic Non-lock Slider Assembly Machine



QLQ-015B

Automatic & Semi-automatic Non-lock Slider Assembly Machine (standard configuration)

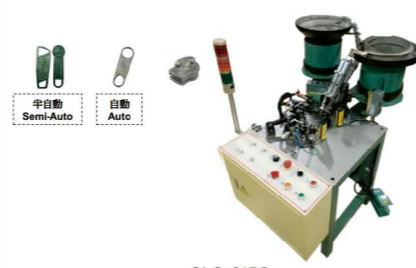

QLQ-015C

Automatic & Semi-automatic Non-lock Slider Assembly Machine (high configuration)

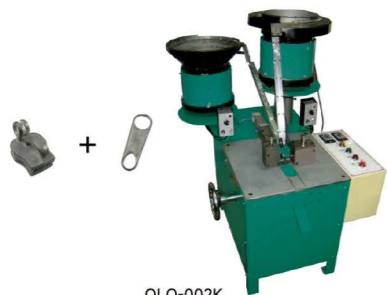

QLQ-002K

Automatic Non-lock (keyhole type) Slider Assembly Machine



QLQ-016

Semi-automatic Non-lock (keyhole type) Slider Assembly Machine (for fancy puller)



QLQ-005

Automatic Non-lock Slider with Double Pullers Assembly Machine

11.2 Italy Type Slider Assembly Machine



QLQ-006

Automatic Slider Body De-burr/Broaching Machine (for 1 pc of slider body)



inlay type

QLQ-023

Automatic & Semi-automatic Italy Type Slider Assembly Machine



drop type

QLQ-023A

Automatic & Semi-automatic Italy Type Slider Assembly Machine

11.3 Auto Spring-lock Slider Assembly Machine (3 components)



QLQ-010

Semi-automatic Slider Assembly Machine (3 components)

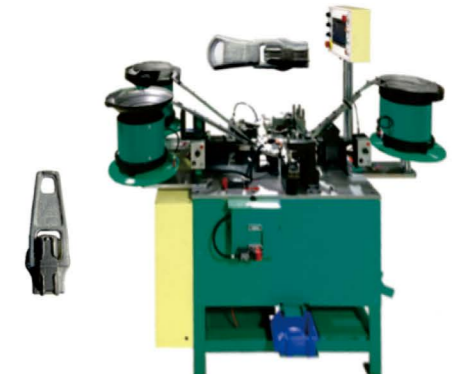

QLQ-028

Automatic & Semi-automatic Spring-lock Slider Assembly Machine (3 components)

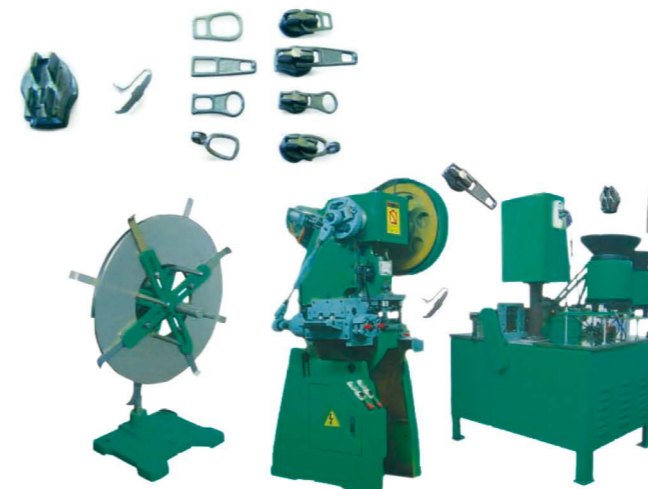

QLQ-SL100

Automatic Spring-lock Slider Pressing + Assembly Machine (3 components) (including wire frame, wire feeding device, 6.3T pressing machine, spring pressing mould and slider assembly machine)



QLQ-001

Automatic Pin-lock Slider Body & Puller Assembly Machine

11.4 Pin-lock Slider Assembly Machine

11.5 Slider Part Selecting Machine



QLQ-102

Automatic Box/Pin Selecting Machine



QLQ-022

Empty Cap Selecting Machine



QLQ-101

Needle/Monkey Selecting Machine

11.6 Auto-lock Slider Assembly Machine (5 components)



QLQ-003
Automatic Cap & Spring
Assembly Machine



QLQ-032
Automatic Cap & Spring Assembly Machine
(punched spring type)



QLQ-006
Automatic Slider Body
De-burr/Broaching Machine
(for 1 pc of slider body)



QLQ-061
Automatic Slider Body De-burr/
Broaching Machine
(for 2 pcs of slider bodies)



QLQ-004
Semi-automatic Auto-lock Slider
Assembly Machine
(5 components, 2 points, Y shape needle)



QLQ-017A
Semi-automatic Auto-lock Slider
Assembly Machine (5 components,
4 points, Y shape/C shape needle)



inlay type
镶件式

QLQ-018C
Automatic & Semi-automatic Auto-lock
Slider Assembly Machine
(5 components, 2 points, Y shape needle)



QLQ-037A
Automatic & Semi-automatic Auto-lock
Slider Assembly Machine
(with de-burr/broaching function)
(5 components, 4 points, C shape needle)



inlay type

QLQ-025
Automatic & Semi-automatic Auto-lock Slider
Assembly Machine
(5 components, 4 points, Y shape needle)



channel type

QLQ-025B
Automatic & Semi-automatic Auto-lock Slider
Assembly Machine
(5 components, 4 points, Y shape needle)



channel type

QLQ-025A
Automatic & Semi-automatic Auto-lock Slider
Assembly Machine
(5 components, 4 points, C shape needle)

11.7 Invisible Slider Assembly Machine



QLQ-011
Automatic Invisible Slider Body
De-burr/Broaching Machine
(I shape, for cleaning mouth height & width)



QLQ-012
Automatic Invisible Slider Body
De-burr/Broaching Machine
(Y shape, for cleaning tape slot, centre column)



QLQ-009
Automatic Invisible Slider Body De-burr/Broaching
Machine (for cleaning mouth height & width, tape
slot, centre column, normal de-burr result)



QLQ-029
Automatic Invisible Slider Body
De-burr/Broaching Machine (for cleaning
mouth height & width, tape slot, centre
column, good de-burr result, 2 pieces/time)



QLQ-020
Automatic Invisible Puller & Triangle Ring
Assembly Machine



QLQ-030
Automatic Invisible Slider Assembly Machine

11.8 Zinc YG Slider Assembly Machine (normal type)



QLQ-001YG
Automatic Zinc YG Slider Body & Puller
Assembly Machine



QLQ-031
Automatic & Semi-automatic Zinc YG Slider Body
& Puller Assembly Machine



QLQ-013D
Automatic Zinc YG Slider & Spring
Assembly Machine

11.9 Zinc YG Slider Assembly Machine (riveted type)



QLQ-001YG
Automatic Zinc YG Slider Body & Puller Assembly Machine



QLQ-013A
Automatic Zinc YG Slider & Spring Assembly Machine
(riveted type)

11.10 Brass Cap Slider Assembly Machine



QLQ-014
Automatic Brass Cap Slider + Pin Assembly Machine



QLQ-027
Automatic Brass Cap Slider Assembly Machine

11.11 Other Slider Assembly Machine



QLQ-021
Semi-automatic Hook +
Special Puller Slider Assembly Machine



QLQ-021A
Automatic Hook + Special Puller
Slider Assembly Machine



QLQ-026D
Automatic & Semi-automatic Flat Puller
(flat puller) + Fancy Puller Slider
Assembly Machine

12 Long-chain Zipper Manufacturing Machine

12.1 Zipper Centre Cord Machine

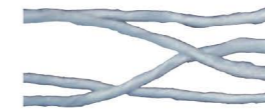

QLQ-CC16M
Automatic Zipper Centre Cord Making Machine
(16 heads)



QLQ-CC8M
Automatic Zipper Centre Cord Making Machine
(8 heads)

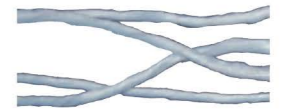

QLQ-SCCM
Automatic Zipper Centre Cord Making Machine
(single twisted, new type)
(Customer can choose the quantity of bobbin.)



QLQ-DCCM
Automatic Zipper Centre Cord Making Machine
(double twisted, new type)
(Customer can choose the quantity of bobbin.)



QLQ-WCCM
Automatic Zipper Weaving Centre Cord Machine



QLQ-CCRM
Automatic Zipper Centre Cord Rolling Machine
/Bobbin Machine

12.2 Zipper Tape Machine



QLQ-YWM
Automatic Yarn Warming Machine



QLQ-NLM
Automatic Zipper Needle Loom Machine
(8 tapes/10 tapes/12 tapes are available)



QLQ-NLM
Automatic Zipper Needle Loom Machine
(20 tapes/24 tapes)



Yarn Bobbin (convex shaft type, 350*271mm)



Yarn Bobbin (bearing type, 355*255mm)

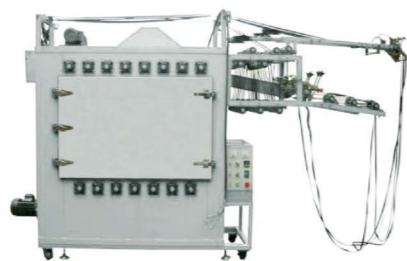

QLQ-4ZTIM/QLQ-6ZTIM
Automatic Zipper Tape Ironing Machine
(4 tapes/6 tapes, one chamber)



QLQ-ZTIM-2
Automatic Zipper Tape Ironing Machine
(new type, 4 tapes, two chambers)



QLQ-SFM-1
Tape/Zipper Shape Fixing Machine (before dyeing, there are 3 models for choosing)
1- only for tape 2-only for zipper 3-for both tape & zipper



QLQ-SFM-2
Tape/Zipper Shape Fixing Machine
(after dyeing, there are 3 models for choosing)



QLQ-ZDM
Dyeing Machine



Bobbin of Dyeing Machine



QLQ-TZIM
Automatic Tape & Zipper Ironing
Machine (two lines)



QLQ-NIIM-1
Automatic Nylon & Invisible Zipper
Ironing Machine (one chamber)

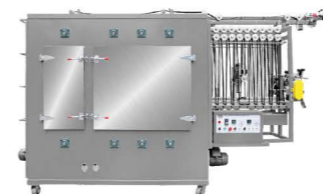

QLQ-NIIM-2
Automatic Nylon & Invisible Zipper
Ironing Machine
(new type, two chambers)



QLQ-SFM
Tape/Zipper Shape Fixing
Machine (after dyeing, there are 3
models for choosing)



QLQ-LCWM
Automatic Long-chain Zipper
Winding Machine



QLQ-LUCM
Automatic Long-chain Uncoiling Machine
(for zipper & tape)

12.3 Nylon Long-chain Zipper Machine



QLQ-MMM
Monofilament Manufacturing Machine



QLQ-CFM-1
Automatic Nylon Zipper
Coil Forming Machine
(small bobbin)



QLQ-CFM-2
Automatic Nylon
Zipper Coil Forming
Machine (big bobbin)



QLQ-CFM-3
Automatic Nylon Zipper
Coil Forming Machine
(horizontal type)



QLQ-NLSM
Automatic Zipper
Sewing Machine
(this photo shows 2 sets)



QLQ-SDTM
Sample Dyeing Test
Machine



QLQ-BWMD
Automatic Tape/Nylon Zipper
Bobbin Winding Machine
(for dyeing machine)

12.4 Plastic Long-chain Zipper Machine



QLQ-DMM
Automatic POM Material Color Mixing
Machine (50kg, 100kg, 150kg...)

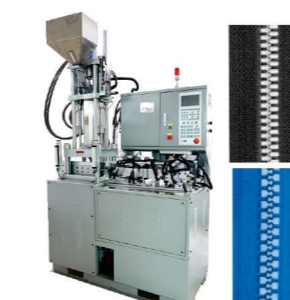

QLQ-DTM
Automatic Plastic Zipper Teeth
Injection Machine



QLQ-DCM
Automatic Plastic Zipper Waste
Crushing Machine

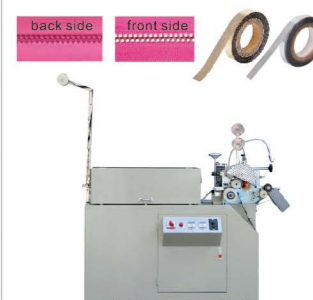

QLQ-PSFSM-1
Automatic Plastic Zipper Shiny
Film Sealing Machine (old model)



QLQ-PSFSM-2
Automatic Plastic Zipper Shiny
Film Sealing Machine (new model)



QLQ-DMPM
Automatic Plastic Zipper Mirror
Face Polishing Machine



QLQ-DUVM
Automatic Metallic Plastic
Zipper UV Lacquer Machine

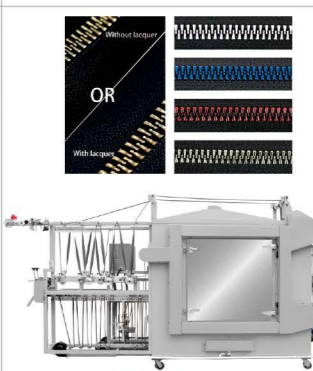

QLQ-DMLM
Automatic Metallic Plastic
Zipper Lacquer Machine

12.5 Metal Long-chain Zipper Machine



QLQ-YTFM
Automatic Metal Zipper Y Teeth Wire Manufacturing Machine

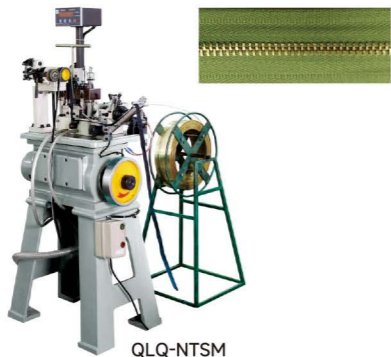

QLQ-NTSM
Automatic Metal Zipper Normal Teeth Stamping Machine



QLQ-RTSM
Automatic Metal Zipper Riri Teeth/Corn Teeth Stamping Machine



QLQ-YTSM-1
Automatic Metal Zipper Y Teeth Stamping Machine (single head)



QLQ-YTSM-2
Automatic Metal Zipper Y Teeth Stamping Machine (double heads)



QLQ-YTSM-3
Automatic Metal Zipper Y Teeth Stamping Machine (double heads, 3 in 1 model)



QLQ-10THPM
Automatic Metal Zipper Teeth-head Intelligent All-around Polishing Machine (single side, 10 pcs wheels)



QLQ-24THPM
Automatic Metal Zipper Teeth-head Intelligent All-around Polishing Machine (double sides, 24 pcs wheels)



QLQ-C8P
Automatic Metal Zipper Chamfering Machine (8 heads)



QLQ-F12P
Automatic Metal Zipper Surface Intelligent Polishing Machine (12 pcs wheels)



QLQ-FCPM
Automatic Metal Zipper Surface Composite Polishing Machine (24 pcs abrasive paper wheels, function: clean the stamping track on the normal zipper)



QLQ-F24P
Automatic Metal Zipper Surface Intelligent Polishing Machine (24 pcs brass wheels, has better effect for polishing Y teeth & Riri teeth zipper)



Adjustment-free Fiber Wheel Refined Polishing Machine



QLQ-BPC
Brass Powder Collector

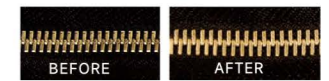

QLQ-MFPM
Automatic Metal Zipper Mirror Face Polishing Machine



QLQ-CMBP
Automatic Metal Zipper Cleaning Machine (before plating)

Shaft can be taken out model



Shaft can't be taken out model

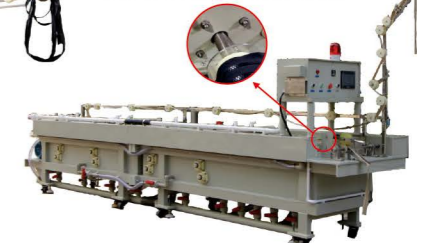

Automatic Metal Zipper Plating Machine
Note: Above two models are available for your choosing whatever shiny gold plating machine, single chemical tank plating machine or double chemical tanks plating machine. Output: 800-1200M/H, 1500-2000M/H, 2000-2500M/H are available.



Auto Chemical Feeding System



Ultrasonic

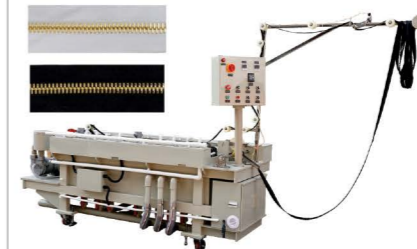

QLQ-GPM-1
Automatic Metal Zipper Shiny Gold Plating Machine (about 800-1200M/H)



QLQ-GPM-2
Automatic Metal Zipper Shiny Gold Plating Machine (1500-2000M/H & 2000-2500M/H are available)

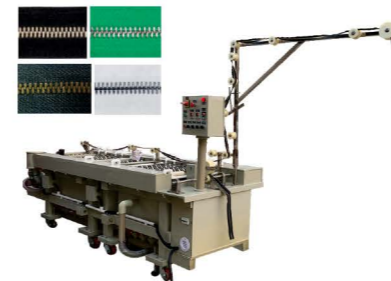

QLQ-CCPMS-1
Automatic Metal Zipper Chemical Cold Plating Machine (with one Chemical Tank) (about 800-1200M/H)



QLQ-CCPMS-2
Automatic Metal Zipper Chemical Cold Plating Machine (with one chemical tank) (1500-2000M/H & 2000-2500M/H are available)

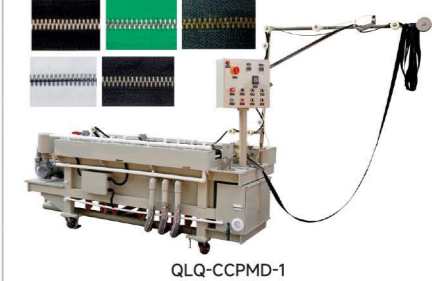

QLQ-CCPMD-1
Automatic Metal Zipper Chemical Cold Plating Machine (with two chemical tanks) (about 800-1200M/H)



QLQ-CCPMD-2
Automatic Metal Zipper Chemical Cold Plating Machine (with two chemical tanks) (1500-2000M/H & 2000-2500M/H are available)



QLQ-EHPM
Automatic Metal Zipper Electric Hot Plating Machine (single line, new model) (about 400M/H)



QLQ-CMAP
Automatic Metal Zipper Cleaning & Color Fixing Machine (after plating)

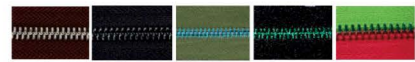

QLQ-MLM
Automatic Metal Zipper Surface Multifunctional Crystal Lacquer Machine (one line, one chamber)

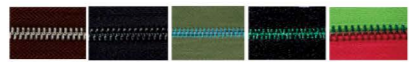

QLQ-MLM2-1
Automatic Metal Zipper Surface Multifunctional Crystal Lacquer Machine (one line, two chambers)

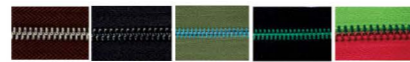

QLQ-MLM2-2
Automatic Metal Zipper Surface Multifunctional Crystal Lacquer Machine (two lines, two chambers)



QLQ-THLM
Automatic Metal Zipper Teeth-head Lacquer Machine (single cycle type available & double cycle type for choosing)



QLQ-THWM
Automatic Metal Zipper Teeth-head Waxing Machine



QLQ-MZPM
Automatic Metal Zipper Pressing Machine

12.6 Waterproof Long-chain Zipper Machine

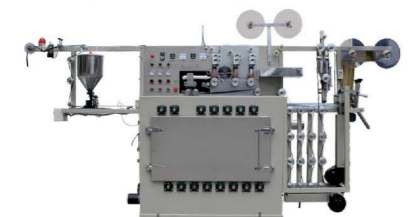

QLQ-WZGFSM
Automatic Waterproof Zipper Gumming & Film Sealing Machine (2 in 1 model, PVC/TPU/PU available)

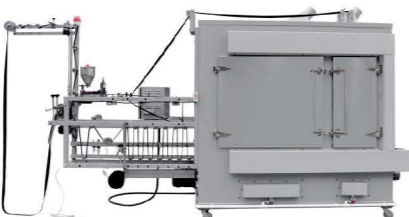

QLQ-WZGM
Automatic Waterproof Zipper Gumming Machine



QLQ-WZFSM
Automatic Waterproof Zipper Film Sealing Machine (PVC/TPU/PU are available)



QLQ-WZSM
Automatic Waterproof Zipper Middle Separating Machine



QLQ-WZEM
Automatic Waterproof Zipper Embossing Machine (one line & two lines for choosing)



QLQ-WZWM
Automatic Waterproof Zipper Winding Machine

13 Finished Zipper Manufacturing Machine

13.1 Nylon Open-end Finished Zipper Machine



QLQ-NGMC-1
Automatic Nylon Zipper Double Trimming Gapping M/C (long model)



QLQ-NGMC-2
Automatic Nylon Zipper Double Trimming Gapping M/C (short model)



QLQ-UFSM
Automatic Nylon Zipper Ultrasonic Film Sealing M/C



QLQ-HPM
Automatic Nylon Zipper Hole Punching M/C



QLQ-UHPM
Automatic Nylon Zipper Ultrasonic Hole Punching M/C



QLQ-SMM-1
Automatic Nylon Zipper Single Side Slider Mounting M/C (normal mounting model)



QLQ-SMM-2
Automatic Nylon Zipper Single Side Slider Mounting M/C (side mounting model)

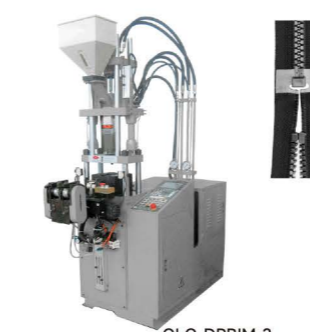

QLQ-DPBM-2
Automatic Zipper Open-end Injection M/C (for zipper with/without slider)

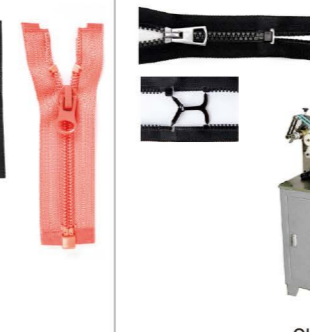

QLQ-DPCM
Automatic Zipper Open-end Injection Waste Material Picking & Zipper Combining M/C



QLQ-DPCM
Automatic Zipper Open-end Injection Waste Material Picking & Crushing Machine M/C



QLQ-PBMM
Automatic Nylon Zipper Pin Box Fixing M/C



QLQ-SPMM
Semi-automatic Nylon Zipper Pin Fixing M/C



QLQ-SBMM
Semi-automatic Nylon Zipper Box Fixing M/C



QLQ-PPMM
Automatic Nylon Zipper Pin Pin Fixing M/C



QLQ-SPPM
Semi-automatic Nylon Zipper
Pin Pin Fixing M/C



QLQ-SMM
Automatic Nylon Zipper Slider
Mounting M/C



QLQ-TSM
Automatic Nylon Zipper Top Stop M/C
(by aluminum top stop wire)



QLQ-SOCM-2
Semi-automatic Nylon Zipper Ultrasonic Open-end
Cutting M/C



QLQ-OCM-3
Automatic Nylon Zipper Open-end Cutting M/C
(with labour hand)



QLQ-OCM-4
Automatic Nylon Zipper Ultrasonic Open-end
Cutting M/C (with labour hand)



QLQ-STSM-1
Semi-automatic Nylon Zipper Top Stop M/C
(by aluminum top stop wire)



QLQ-NUTM
Automatic Nylon Zipper Ultrasonic "U" Shape
Top Stop M/C (by transparent top stop wire,
with one welding head)



QLQ-SNUTM
Semi-automatic Nylon Zipper Ultrasonic "U"
Shape Top Stop M/C
(by transparent top stop wire)

13.2 Nylon Closed-end Finished Zipper Machine



QLQ-NDGM-1
Automatic Nylon Zipper Double Trimming
Gapping M/C (long model)



QLQ-NDGM-2
Automatic Nylon Zipper Double Trimming
Gapping M/C (short model)



QLQ-NDGBM
Automatic Nylon Zipper Double Trimming
Gapping & Bottom Stop M/C (by aluminum
bottom stop wire)



QLQ-OCM-1
Automatic Nylon Zipper Open-end Cutting
M/C



QLQ-SOCM-1
Semi-automatic Nylon Zipper Open-end
Cutting M/C



QLQ-OCM-2
Automatic Nylon Zipper Ultrasonic
Open-end Cutting M/C



QLQ-BSM
Automatic Nylon Zipper Bottom Stop M/C
(by aluminum bottom stop wire)

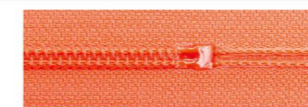

QLQ-UBSM
Automatic Nylon Zipper Ultrasonic Bottom
Stop M/C (by transparent bottom stop wire)



QLQ-UMBSM
Automatic Nylon Zipper Ultrasonic Teeth Melting
Bottom Stop M/C (melt teeth directly, without wire)



QLQ-SMM
Automatic Nylon Zipper Slider Mounting M/C



QLQ-TSM
Automatic Nylon Zipper Top Stop M/C
(by aluminum top stop wire)



QLQ-STSM-1
Semi-automatic Nylon Zipper Top Stop M/C
(by aluminum top stop wire)



QLQ-ZCM-3
Automatic Nylon Zipper Closed-end Zigzag Cutting M/C
(with labour hand)



QLQ-ZCM-4
Automatic Nylon Zipper Ultrasonic Closed-end Zigzag Cutting M/C
(with labour hand)

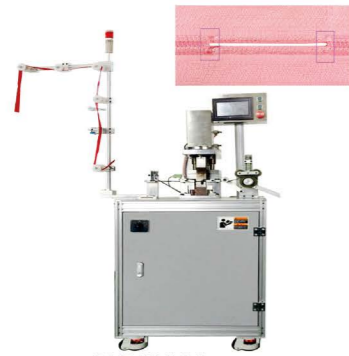

QLQ-NUMM
Automatic Nylon Zipper Ultrasonic 4-points
Teeth Melting M/C



QLQ-NUTM
Automatic Nylon Zipper Ultrasonic "U" Shape Top
Stop M/C (by transparent top stop wire,
with one welding head)



QLQ-SNUTM
Semi-automatic Nylon Zipper Ultrasonic "U"
Shape Top Stop M/C (by transparent top stop wire)

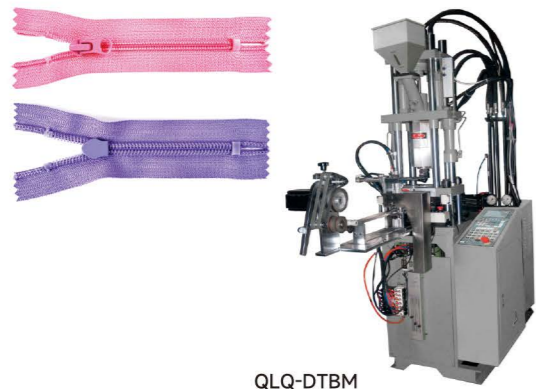

QLQ-DTBM
Automatic Zipper Closed-end Injection M/C

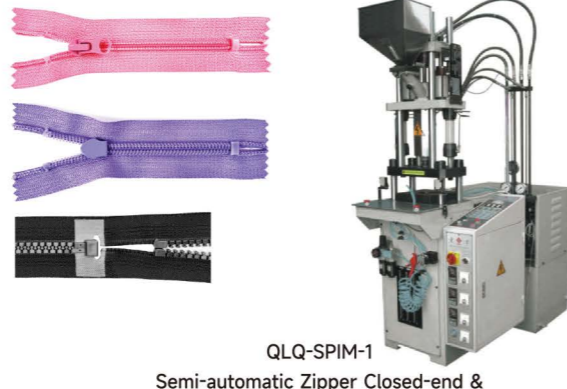

QLQ-SPIM-1
Semi-automatic Zipper Closed-end &
Open-end Injection M/C (for zipper with/without slider)



QLQ-ZCM-1
Automatic Nylon Zipper Closed-end Zigzag
Cutting M/C



QLQ-SZCM-1
Semi-automatic Nylon Zipper Closed-end
Zigzag Cutting M/C



QLQ-ZCM-2
Automatic Nylon Zipper Ultrasonic Closed-end
Zigzag Cutting M/C



QLQ-IGM
Automatic Invisible Zipper Double Trimming
Gapping M/C (long model)



QLQ-IUBSM
Automatic Invisible Zipper Ultrasonic Teeth
Melting Bottom Stop M/C (melt teeth directly,
without wire)



QLQ-IDGUBM
Automatic Invisible Zipper Double Trimming
Gapping & Ultrasonic Teeth
Melting Bottom Stop M/C



QLQ-ISMM
Automatic Invisible Zipper Slider Mounting
M/C



QLQ-IUIM
Automatic Invisible Zipper Ultrasonic "I" Shape
Top Stop M/C (by transparent round top stop
wire)



QLQ-IUUM
Automatic Invisible Zipper Ultrasonic "U"
Shape Top Stop M/C (by transparent top
stop wire, with one welding head)

13.3 Invisible Finished Zipper Machine



QLQ-SIUUM
Semi-automatic Invisible Zipper Ultrasonic "U"
Shape Top Stop M/C (by transparent top stop wire)



QLQ-ZCM-1
Automatic Invisible Zipper Closed-end Zigzag
Cutting M/C



QLQ-SZCM
Semi-automatic Invisible Zipper
Closed-end Zigzag Cutting M/C

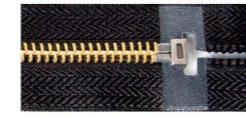

QLQ-PBMM
Automatic Metal Zipper Pin Box Fixing M/C



QLQ-SBMM
Semi-automatic Metal Zipper Box Fixing M/C



QLQ-SPMM
Semi-automatic Metal Zipper Pin Fixing M/C

13.4 Metal Open-end Finished Zipper Machine



QLQ-MGM
Automatic Metal Zipper Gapping M/C
(long model)



QLQ-MDGM-1
Automatic Metal Zipper Double Trimming
Gapping M/C (long model)

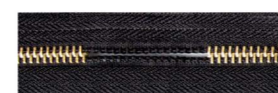

QLQ-MDGM-2
Automatic Metal Zipper Double Trimming
Gapping M/C (short model)



QLQ-PPMM
Automatic Metal Zipper Pin Pin
Fixing M/C



QLQ-SPPMM
Semi-automatic Metal Zipper Pin
Pin Fixing M/C



QLQ-SMM
Automatic Metal Zipper Slider
Mounting M/C



QLQ-SMM-1
Automatic Metal Zipper Single Side
Slider Mounting M/C
(normal mounting model)



QLQ-UFSM
Automatic Metal Zipper Ultrasonic Film
Sealing M/C



QLQ-HPM
Automatic Metal Zipper Hole Punching M/C

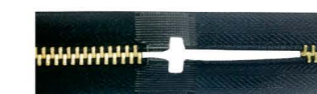

QLQ-UHPM
Automatic Metal Zipper Ultrasonic Hole
Punching M/C

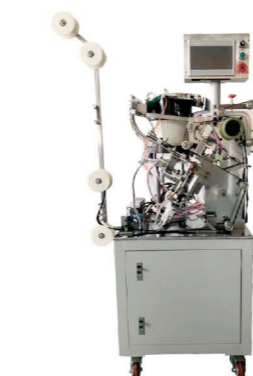

QLQ-SMM-2
Automatic Metal Zipper Single Side
Slider Mounting M/C
(side mounting model)



QLQ-TSM
Automatic Metal Zipper Top Stop
M/C (by brass top stop wire)



QLQ-STSM-2
Semi-automatic Metal Zipper Top
Stop M/C (by brass top stop wire)



QLQ-MUTM
Automatic Metal Zipper Top Stop
M/C (by grain "U" shape top stop)



13.5 Metal Closed-end Finished Zipper Machine



QLQ-SMUTM
Semi-automatic Metal Zipper Top Stop M/C
(by grain "U" shape top stop)



QLQ-METM
Automatic Metal Zipper Top Stop M/C
(by grain European shape top stop)



QLQ-SMETM
Semi-automatic Metal Zipper Top Stop M/C
(by grain European shape top stop)



QLQ-MGM
Automatic Metal Zipper Gapping M/C
(long model)



QLQ-MDGM-1
Automatic Metal Zipper Double Trimming
Gapping M/C (long model)



QLQ-MDGM-2
Automatic Metal Zipper Double Trimming
Gapping M/C (short model)



QLQ-OCM-1
Automatic Metal Zipper Open-end Cutting M/C



QLQ-SOCM-1
Semi-automatic Metal Zipper Open-end
Cutting M/C



QLQ-OCM-2
Automatic Metal Zipper Ultrasonic Open-end
Cutting M/C

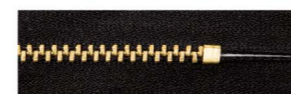

QLQ-BSM
Automatic Metal Zipper Bottom Stop M/C
(by brass bottom stop wire)

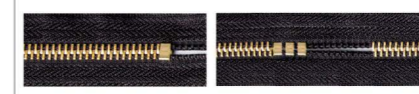

QLQ-HBSM
Automatic Metal Zipper "H" Bottom Stop M/C
(have 1 piece model and multiple pieces model
for choosing)



QLQ-SHBSM
Semi-automatic Metal Zipper "H" Bottom
Stop Fixing M/C



QLQ-SOCM-2
Semi-automatic Metal Zipper Ultrasonic
Open-end Cutting M/C



QLQ-OCM-3
Automatic Metal Zipper Open-end Cutting
M/C(with labour hand)



QLQ-OCM-4
Automatic Metal Zipper Ultrasonic Open-end
Cutting M/C (with labour hand)



QLQ-SMM
Automatic Metal Zipper Slider Mounting M/C



QLQ-TSM
Automatic Metal Zipper Top Stop M/C
(by brass top stop wire)



QLQ-STSM-2
Semi-automatic Metal Zipper Top Stop M/C
(by brass top stop wire)



13.6 Plastic Open-end Finished Zipper Machine



QLQ-MUTM
Automatic Metal Zipper Top Stop M/C
(by grain "U" shape top stop)



QLQ-SMUTM
Semi-automatic Metal Zipper Top Stop M/C
(by grain "U" shape top stop)



QLQ-METM
Automatic Metal Zipper Top Stop M/C
(by grain European shape top stop)

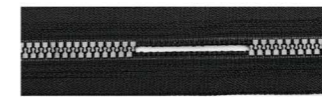

QLQ-DGM
Automatic Plastic Zipper Gapping M/C



QLQ-UFSM
Automatic Plastic Zipper Ultrasonic Film
Sealing M/C



QLQ-HPM
Automatic Plastic Zipper Hole Punching M/C



QLQ-SMETM
Semi-automatic Metal Zipper Top Stop M/C
(by grain European shape top stop)



QLQ-ZCM-1
Automatic Metal Zipper Closed-end
Zigzag Cutting M/C



QLQ-SZCM-1
Semi-automatic Metal Zipper Closed-end
Zigzag Cutting M/C

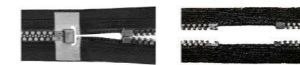

QLQ-DOIM-1
Automatic Plastic Zipper Open-end
Injection M/C
(only for zipper without slider)



QLQ-DOIM-2
Automatic Plastic Zipper Open-end
Injection M/C
(for zipper with/without slider)



QLQ-SDIM-1
Semi-automatic Plastic Zipper
Closed-end & Open-end Injection M/C
(for zipper with/without slider)



QLQ-SDIM-2
Semi-automatic Plastic Zipper Injection M/C
(open-door model, only inject top
stop/bottom stop/pin box/pin pin)



QLQ-ZCM-2
Automatic Metal Zipper Ultrasonic
Closed-end Zigzag Cutting M/C



QLQ-ZCM-3
Automatic Metal Zipper Closed-end Zigzag
Cutting M/C (with labour hand)



QLQ-ZCM-4
Automatic Metal Zipper Ultrasonic Closed-end
Zigzag Cutting M/C (with labour hand)



QLQ-SMM-1
Automatic Plastic Zipper Single Side
Slider Mounting M/C
(normal mounting model)

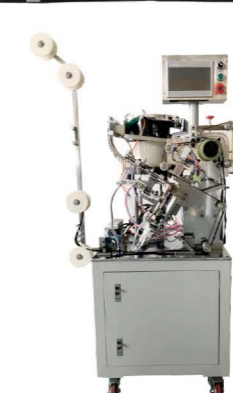

QLQ-SMM-2
Automatic Plastic Zipper Single Side
Slider Mounting M/C
(side mounting model)



QLQ-DPZCM
Automatic Plastic Zipper Open-end
Injection Waste Material Picking &
Zipper Combining M/C

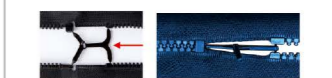

QLQ-DPCM
Automatic Zipper
Open-end Injection Waste Material
Picking & Crushing Machine M/C



QLQ-OCM-1
Automatic Plastic Zipper Open-end
Cutting M/C



QLQ-SOCM-1
Semi-automatic Plastic Zipper Open-end
Cutting M/C



QLQ-OCM-2
Automatic Plastic Zipper Ultrasonic Open-
end Cutting M/C



QLQ-DCIM
Automatic Plastic Zipper Closed-end
Injection M/C



QLQ-SDIM-1
Semi-automatic Plastic Zipper Closed-end &
Open-end Injection M/C
(for zipper with/without slider)



QLQ-SDIM-2
Semi-automatic Plastic Zipper Injection M/C
(open-door model, only inject top
stop/bottom stop/pin box)



QLQ-SOCM-2
Semi-automatic Plastic Zipper Ultrasonic
Open-end Cutting M/C



QLQ-OCM-3
Automatic Plastic Zipper Open-end Cutting
M/C
(with labour hand)



QLQ-OCM-4
Automatic Plastic Zipper Ultrasonic
Open-end
Cutting M/C (with labour hand)

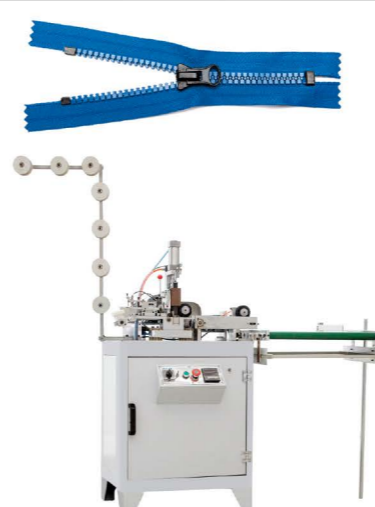

QLQ-ZCM-1
Automatic Plastic Zipper
Closed-end Zigzag Cutting M/C



QLQ-SZCM-1
Semi-automatic Plastic Zipper
Closed-end Zigzag Cutting M/C



QLQ-ZCM-2
Automatic Plastic Zipper Ultrasonic Closed-end
Zigzag Cutting M/C

13.7 Plastic Closed-end Finished Zipper Machine



QLQ-DGM
Automatic Plastic Zipper Gapping M/C

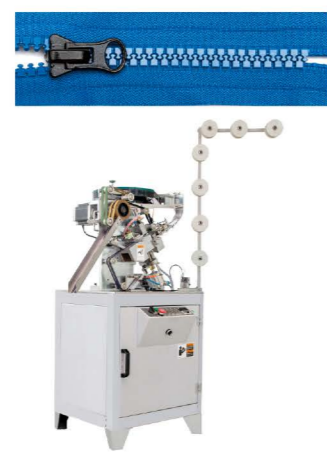

QLQ-SMM
Automatic Plastic Zipper Slider Mounting M/C
(for normal type bottom stop)



QLQ-SMM-2
Automatic Plastic Zipper Slider Mounting
and Zipper Combining M/C
(for flower/hook shape bottom stop)



QLQ-ZCM-3
Automatic Plastic Zipper Closed-end Zigzag
Cutting M/C (with labour hand)

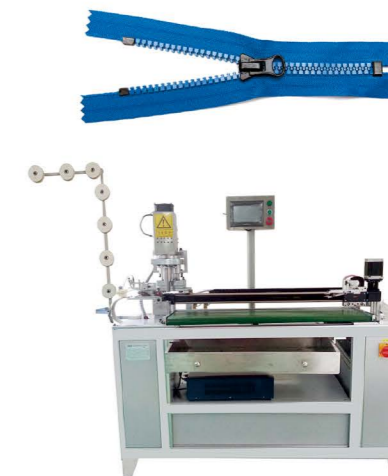

QLQ-ZCM-4
Automatic Plastic Zipper Ultrasonic Closed-end
Zigzag Cutting M/C (with labour hand)

13.8 Special Finished Zipper Machine



QLQ-UCTMM
Automatic Nylon Zipper Ultrasonic
Edge Curling & Teeth Melting M/C



QLQ-SMM-1
Automatic Nylon Zipper Slider Mounting M/C
(used for zipper with 2 sides of bottom stop)



QLQ-DSMM
Automatic Zipper Double Sliders Mounting Machine



QLQ-BSM-1
Automatic Nylon Zipper Special Bottom Stop M/C
(by aluminum bottom stop wire,
with 2 sides of bottom stop)

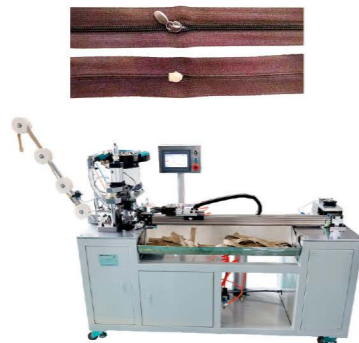

QLQ-SMCM
Automatic Zipper Slider Mounting & Cutting Machine

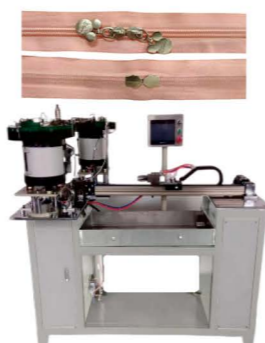

QLQ-DSMCM
Automatic Zipper Double Sliders
Mounting & Cutting Machine

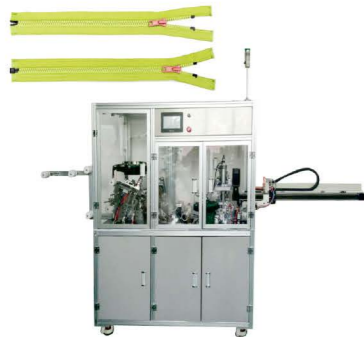

QLQ-SCBM
Automatic Plastic Zipper Slider
Mounting & Ultrasonic Cutting & Box Fixing M/C (3 in 1)



QLQ-CBM
Automatic Plastic Zipper Ultrasonic
Cutting & Box Fixing M/C (2 in 1)



QLQ-ZPM
Zipper Packing Machine

13.9 PVC Without Teeth Zipper Manufacturing Machine



QLQ-PZMM
PVC Without Teeth Zipper Manufacturing Machine



PVC Grain



PVC Color Master Batch

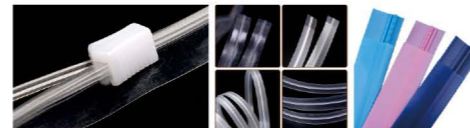

14 Spare Part of Zipper Manufacturing Machine

14.1 Spare Part of Automatic Centre Cord Machine



Stainless Steel Pipe



Multihole Belt



Latitude Needle & Latitude
Needle Seat



Hooked Needle Seat



Balance Wheel

14.2 Spare Part of Automatic Needle Loom Machine



Aluminum Handle



Pole of Needle Block



Yarn Needle



Spring of Weft Yarn



Pressing Wheel

14.3 Spare Part of Automatic Coil Forming Machine



6001 Stabilizing Shaft



Forming Screw



Umbrella Teeth Wheel



Hitting Head



Black Head

14.4 Spare Part of Automatic Sewing Machine



Thread Pressing Plate



Spring Slice



Sewing Needle



Hooked Needle Seat



Top Seat of Cover Plate



Sliding Plate for Adjusting
Needle Space (rear)



Steel Bead



Observed Sleeve for
Adjusting Zipper Size



Roller Turning Wheel



Cover of Roller
Turning Wheel

14.5 Spare Part of Automatic Normal Teeth Stamping Machine

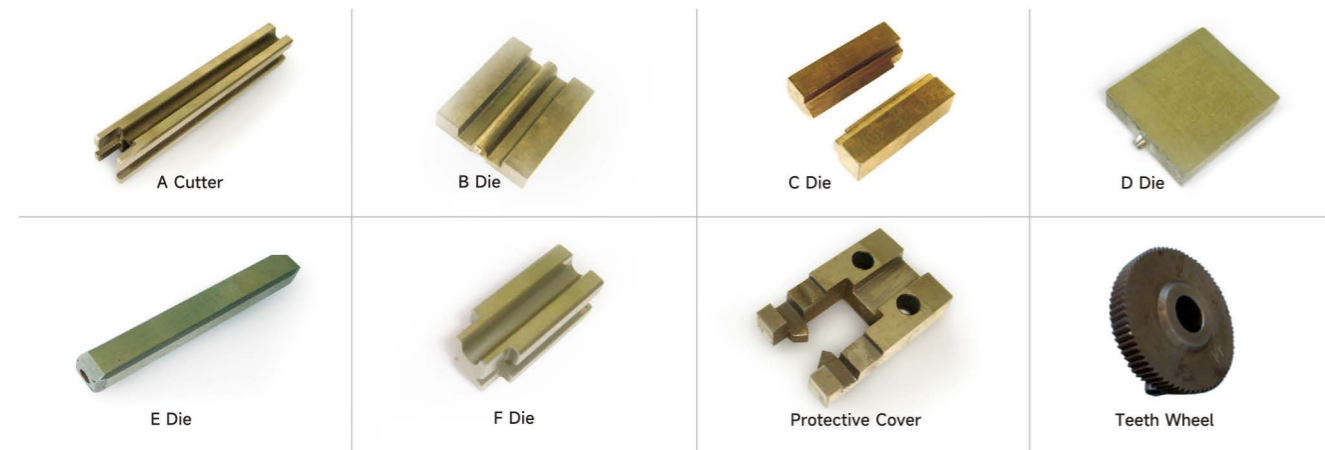

14.6 Spare Part of Automatic Y Teeth Stamping Machine



14.7 Spare Part of Automatic European Teeth Stamping Machine

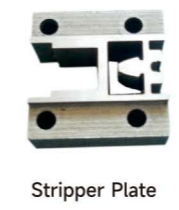

Stripper Plate



Edge Cutter



Middle Cutter



Cupping (E Die)

14.8 Spare Part of Some Finished Zipper Machine



15 Silicone Product Manufacturing Machine



QLQ-SGM
Silicone Gum Machine



QLQ-SCM
Silicone Cutting Machine



QLQ-LSMM
Liquid Silicone Mixing Machine



QLQ-LSVM
Liquid Silicone Vacuum Machine



QLQ-12LSDM
12-color Liquid Silicone Dispensing Machine



QLQ-SOM
Silicone Oven Machine



QLQ-50SHM
50T Single-head Hydraulic Machine



QLQ-50DHM
50T Double-head Hydraulic Machine



16 PVC Product Manufacturing Machine



QLQ-PMM
PVC Mixing Machine



QLQ-PVDM
PVC Vacuum Defoaming Machine



QLQ-PDM
PVC Dispensing Machine



QLQ-POM
PVC Oven Machine



QLQ-PHCM
PVC Heat Sealing Machine



17 Various Moulds Related Machines & Tools



QLQ-HSM
Horizontal Type Sawing Machine



QLQ-SGM
Automatic Surface Grinding Machine



QLQ-PMSGM
Precision Manual Surface Grinding Machine



Grinding Wheel



QLQ-EMM
Express Milling Machine



QLQ-SDM
Small Drilling Machine



QLQ-TM
Tapping Machine (Table model)



QLQ-HSL
Horizontal Semi-automatic Lathe



QLQ-HWCM
High Speed Wire Cutting Machine



QLQ-MWCM
Medium Speed Wire Cutting Machine



QLQ-LWCM
Low Speed Wire Cutting Machine



QLQ-CEMM
CNC Engraving & Milling Machine



QLQ-KGM
Knife Grinding Machine



QLQ-2DEM
2D Engraving Machine



QLQ-3DEM
3D Engraving Machine



QLQ-GM
Grinding Machine



QLQ-EDM
Electric Discharge Machine



QLQ-MSM
Mirror Spark Machine



QLQ-PT
Projector



QLQ-SMCM
Side Milling and Chamfering
Machine-Table Model



QLQ-RHT
Rockwell Hardness Tester



QLQ-LM
Laser Machine

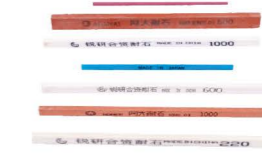

Oilstone



Oil Gypsum

18 Various Button Manufacturing Machines & Material

18.1 Button Machines

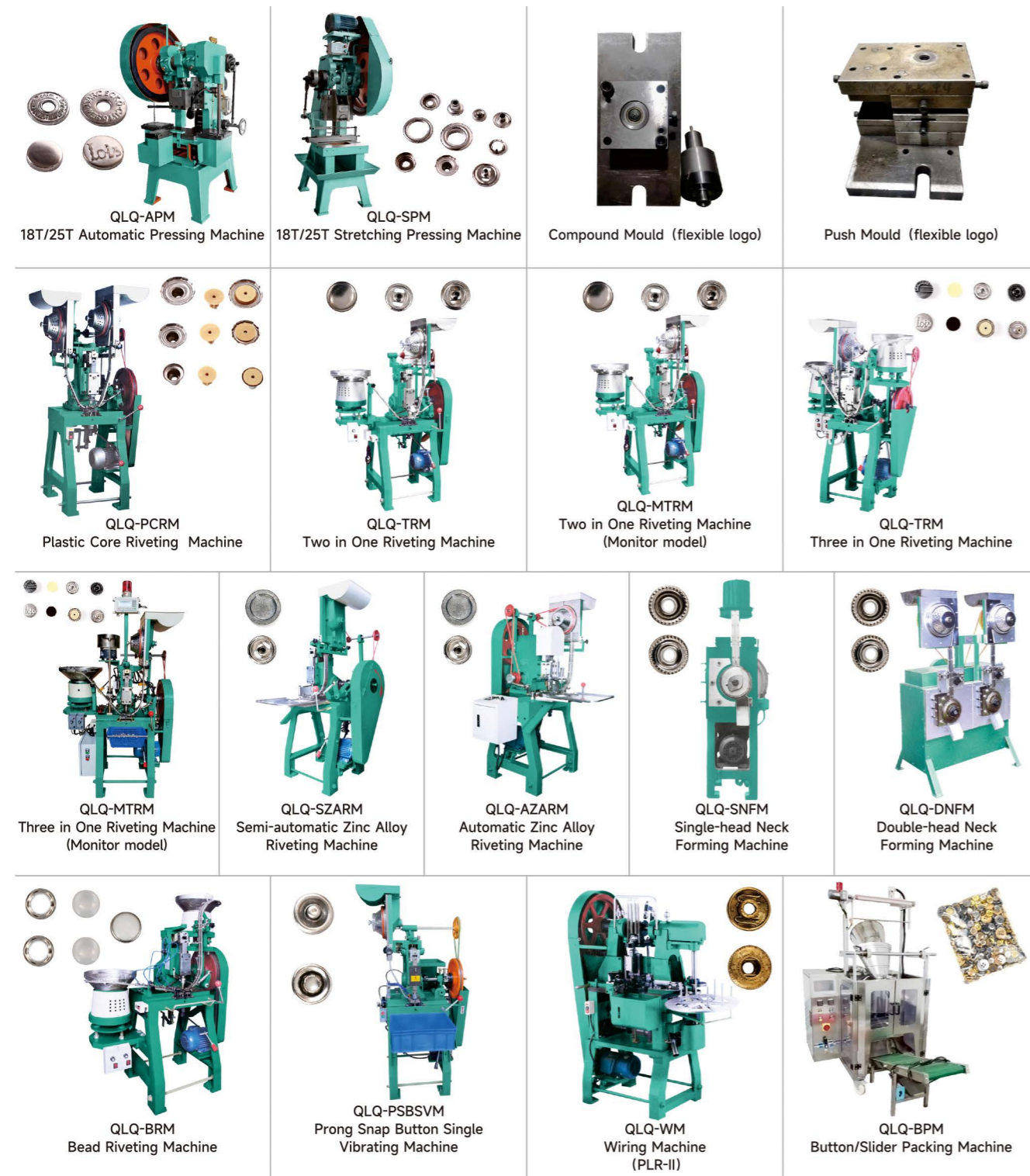

Roll material sizes: 0.2*14mm, 0.2*19mm, 0.2*22mm, 0.2*25mm, 0.23*14mm, 0.23*26mm



19 Various Bag Accessories Manufacturing Machines

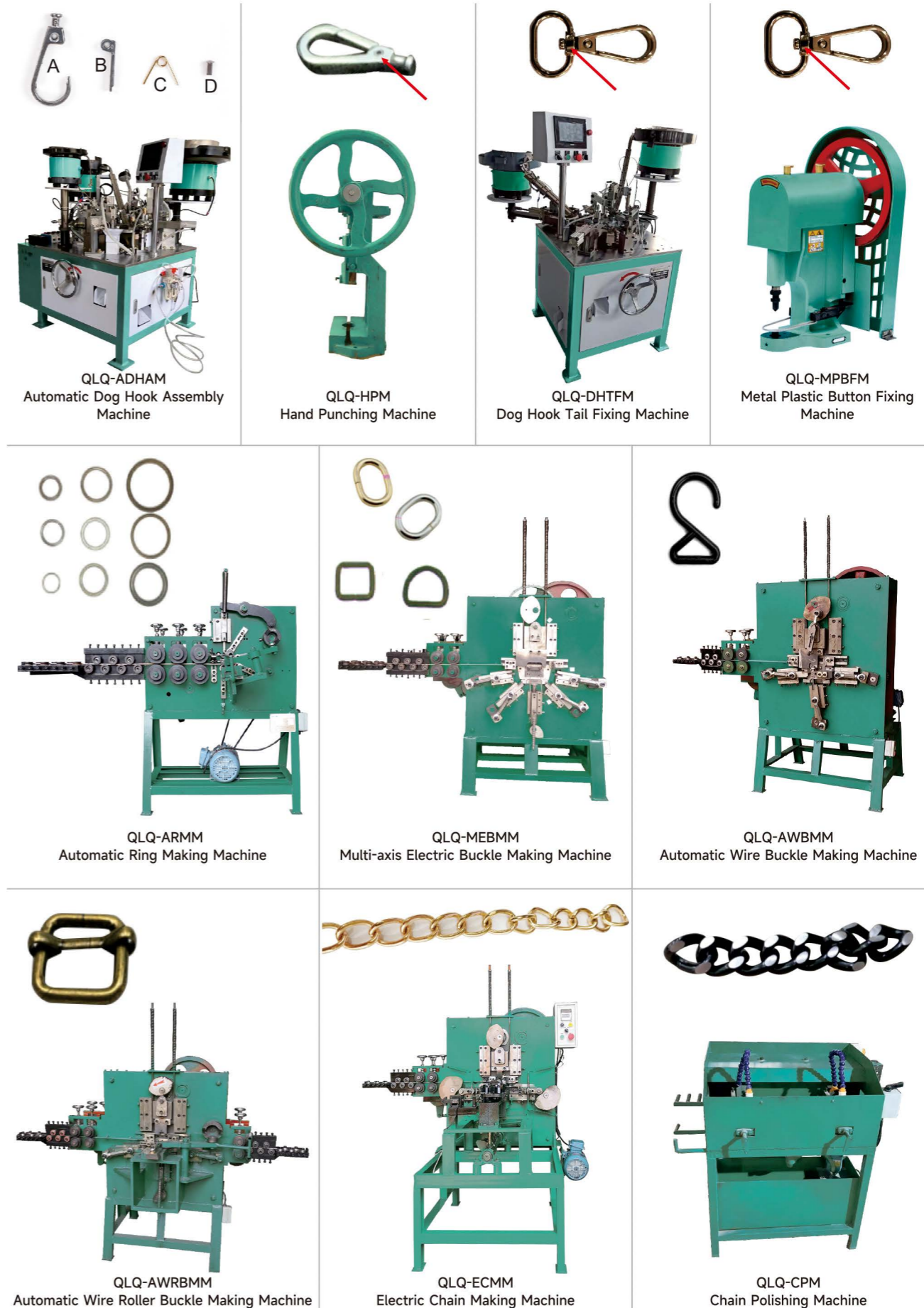

20 Zipper, Slider & Hardware Test Machine



QLQ-ETTM
Automatic Electronic Type Tension
Test Machine



QLQ-RFTM
Automatic Zipper Reciprocating
Fatigue Test Machine



QLQ-STTM
Automatic Slider Torsion Test Machine



QLQ-NDM-1
Automatic Conveyor Belt Needle
Detecting Machine (made in China)



QLQ-NDM-2
Automatic Conveyor Belt Needle
Detecting Machine
(Hashima, imported)



QLQ-SSTM
Automatic Saline Spray
Test Machine



QLQ-LSB
Automatic Standard
Light Source Box



QLQ-DCTM
Automatic Electronic Type Decolorization
Test Machine



QLQ-HPC
Automatic High Precision Colorimeter



QLQ-DWTM
Automatic Dye Washing Fastness Test Machine

21 Jacquard Machine and Crochet Machine

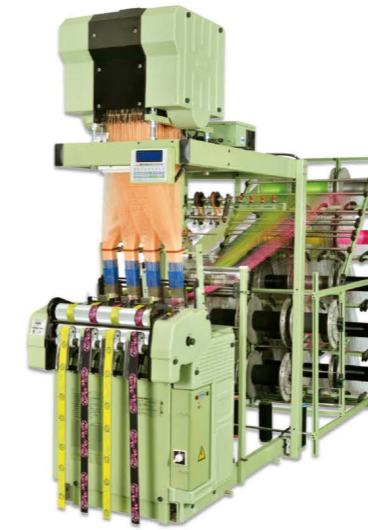

QLQ-CJM-1 Computerized Jacquard Machine (made in China)

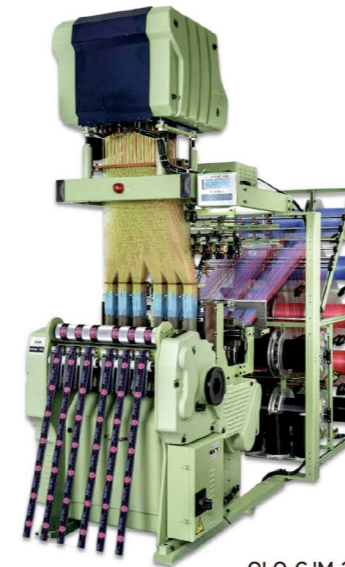

QLQ-CJM-2 Computerized Jacquard Machine (made in Taiwan)

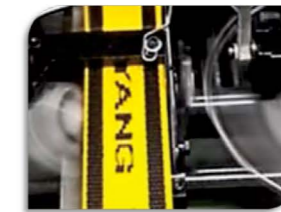

QLQ-CM Crochet Machine



22 Hook & Loop / Velcro Manufacturing Machines



QLQ-VWPM
Velcro Warping Machine



QLQ-VWVM
Velcro Weaving Machine



QLQ-VDM
Velcro Dyeing Machine



QLQ-VRM
Velcro Raising Machine (loop)



QLQ-VGSM
Velcro Gluing & Setting Machine (hook)

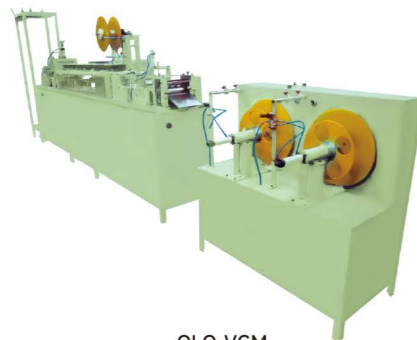

QLQ-VGM
Velcro Gluing Machine



QLQ-VMHMM
Velcro Mushroom Head Molding Machine

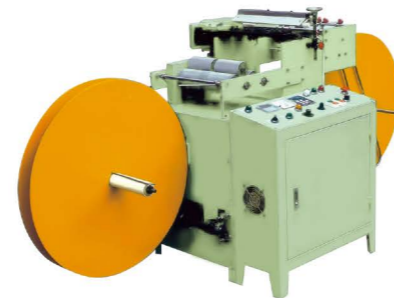

QLQ-VHCM
Velcro Hook Cutting Machine

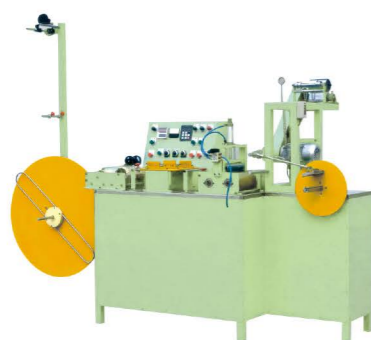

QLQ-VSM
Velcro Slitting Machine



QLQ-VRM
Velcro Rolling Machine

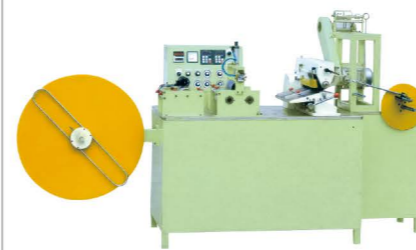

QLQ-VSRM
Velcro Slitting & Rolling Machine

23 Centrifugal Die Casting Series Manufacturing Machines & Raw Materials



QLQ-SMPM
Semi-automatic Mould Pressing Machine



QLQ-AMPM
Automatic Mould Pressing Machine



QLQ-EMF
Electric Melting Furnace



QLQ-INCMF
Intelligent NC Melting Furnace



QLQ-SCM
Semi-automatic Centrifugal Machine



QLQ-ACM
Automatic Centrifugal Machine

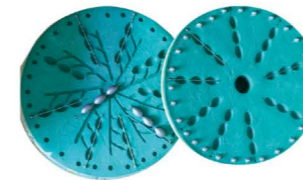

Steel Wire Fish Mould



Lead Hook Mould



Lead Pendant Mould



24 Raw Material & Accessory for Zipper & Slider

24.1 Yarn (150D48F, 300D96F, ...low elastic yarn & network yarn)



24.2 Sewing Thread (suitable for sewing zipper tape & monofilament chain)



24.3 Centre Cord

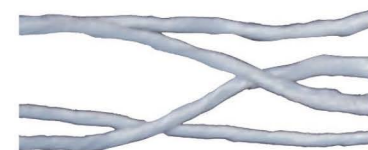
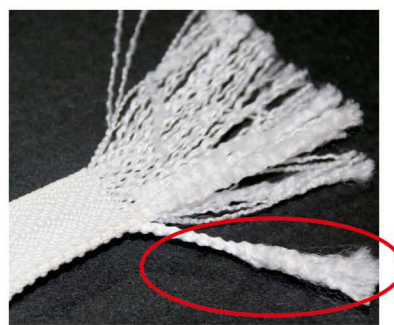

Single Twisted Centre Cord



Double Twisted Centre Cord



Weaving Centre Cord

24.4 Monofilament

3#:0.48mm, 0.50mm, 5#:0.68 mm, 7#:0.72mm, 0.74mm, 8#:0.78mm, 10#:1.05mm, other sizes are available to be made according to customer's requirement)



24.5 POM Plastic Grain (M90, M270) & ABS



POM



POM



ABS



ABS



Color Masterbatch
色母



Color Masterbatch
色母

24.6 Transparent Film/Semi-transparent Film

Standard size:15mm/18mm/20mm/22mm*0.13-0.16mm, other sizes are available to be made according to customer's requirement

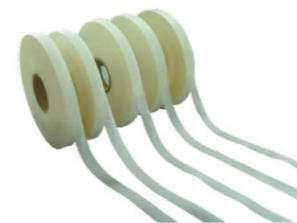

24.7 Fabric Film

Standard size:15mm/18mm/20mm/22mm*0.16-0.18mm, other sizes are available to be made according to customer's requirement

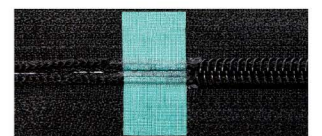

24.8 Golden/Silver Film



24.9 Waterproof Film



TPU



PU



PU



PU

24.10 H Bottom Stop

(size: 3#, 4#, 5#, 8#, 10#, material: brass, aluminum, zinc, stainless steel)



K Shape Brass Bottom Stop



X Shape Brass Bottom Stop



X Shape Aluminum Bottom Stop



X Shape Zinc Bottom Stop

24.11 Claw Bottom Stop

(size: 3#, 4#, 5#, 8#, 10#, material: brass, aluminum, iron)



Brass 4 Feet Claw Bottom Stop



Brass 6 Feet Claw Bottom Stop



Iron 3 Feet Claw Bottom Stop



Iron 4 Feet Claw Bottom Stop

24.12 Grain Top Stop

(size: 3#, 4#, 5#, 8#, 10#, material: brass, aluminum, zinc, stainless steel)



Brass U Shape Top Stop



Brass European Shape Top Stop



Aluminum European Shape Top Stop



Zinc U Shape Top Stop (golden plating color)



5#, brass top stop, European type

24.13 Slider Pressing Part



Y Shape Needle



C Shape Needle



Spring Cap



Hook



Universal / Flexible Hook



Flat Puller



Normal Brass Puller



Brass Cap for Italy Slider



Spring for Zinc YG Slider



Invisible Slider Parts

25 Wire/Strip for Zipper & Slider

25.1 Flat Wire for Normal Teeth Stamping Machine

(material: brass, aluminum, stainless steel, iron)

Zipper Size	Normal Size	Small Size
2#	0.6*3.10	
3#	0.75* 3.18	0.75* 3.0
4#	0.90*3.50	0.90*3.18
5#	0.90*3.95	0.90*3.50
7#	1.10*4.40	
8#	1.25 x 4.6	1.10* 4.20
10#	1.45*5.70	

Note: Other sizes are available to be made according to customer's requirement.



25.2 Y Wire for Y Teeth Stamping Machine

(material: brass, aluminum, stainless steel)



25.3 Bottom Stop Wire

(material: brass, aluminum which can be plated to be black nickel, brass, antique brass and other colors)

Zipper Size	Bottom Stop Wire Size (mm)
2#	2.4*0.4
3#	3.0*0.4, 3.0*0.35, 3.0*0.45, 3.0*0.5
5#	3.5*0.4, 3.5*0.45, 3.5*0.5, 3.6*0.4, 3.6*0.45, 3.6*0.5, 4.0*0.5, 3.8*0.4
8#	4.5*0.45, 4.5*0.5, 4.8*0.6, 4.8*0.55, 4.2*0.6
10#	6.0*0.6, 5.9*0.5, 5.9*0.55, 4.8*0.6

Note: Other sizes are available to be made according to customer's requirement.



25.4 Top Stop Wire

(material: brass, aluminum which can be plated to be black nickel, brass, antique brass and other colors)

Zipper Size	Brass Top Stop Wire Size (mm)
2#	2.1*0.7
3#	2.2*0.85, 2.2*0.8, 2.2*1.0, 2.2*1.25, 2.1*0.7, 2.0*0.85
4#	2.2*0.85, 2.4*0.9, 2.2*1.0
5#	2.6*1.0, 3.0*0.85, 2.4*0.9, 2.6*0.85, 3.0*0.8, 3.0*1.0, 3.0*0.95, 2.5*1.0, 2.5*1.4, 3.0*1.2, 3.0*0.9
8#	3.1*1.2, 3.8*1.2, 4.0*1.1, 4.0*1.25
10#	4.0*1.25, 4.0*1.4, 4.0*1.1

Note: Other sizes are available to be made according to customer's requirement.

Zipper Size	Aluminum Top Stop Wire Size (mm)
2#	1.78*0.36
3#	1.8*0.4, 1.8*0.35, 1.78*0.36
5#	2.4*0.4, 2.4*0.35, 2.4*0.45, 2.5*0.4
8#	3.5*0.4, 3.6*0.4, 3.6*0.5, 3.0*0.4
10#	3.6*0.4, 3.6*0.5, 3.5*0.4

Note: Other sizes are available to be made according to customer's requirement.



25.5 Transparent Top & Bottom Stop Wire

Zipper Size	Transparent Top Stop Wire Size (mm)
13#	1.9*0.5
N3#	1.70*0.65, 1.9*0.75
N5#	2.4*0.95



Zipper Size	Transparent Bottom Stop Wire Size (mm)
used for all sizes of zippers	7.6*0.60



Zipper Size	Transparent Top Stop Round Wire Size (mm)
used for all sizes of zippers	0.90, 1.0, 1.05, 1.2, 1.5

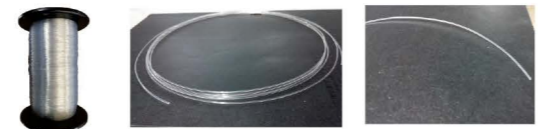

25.6 Other Wire

(following sizes are standard sizes, other sizes are available to be made according to customer's requirement)



3# Size: 0.11*1.70mm
5# Size: 0.11*2.20mm
8#&10# Size: 0.13*3.15mm

Stainless Steel Wire for Cap Spring
(this wire is inserted to the cap of 5 components auto-lock slider)



Size: 0.25*17.50mm
0.25*19.10mm

Stainless Steel Wire for 3 Components Auto-lock Slider



Pin Wire for Brass Cap Slider



Spring Wire for Brass YG Slider



Wire for Some Slider Accessories

(Y shape/C shape needle/monkey, hook, flat puller, material: brass, iron.)



Reference Size:
Y Shape Needle: 0.90*19mm
C Shape Needle: 0.8*25mm
Hook: 0.80*45mm
Flat Puller: 0.80*31mm

26 Various of Sliders & Pin Box

26.1 Plastic Slider



26.2 YG Slider (material: brass, iron, zinc, stainless steel)

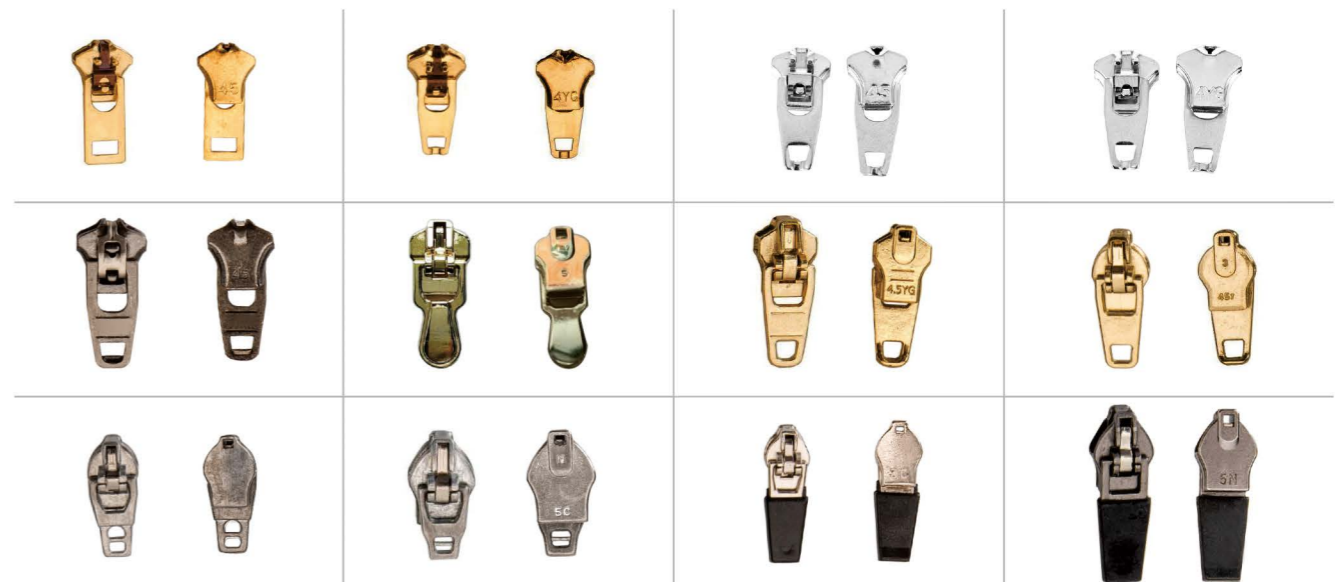

26.3 Non-lock Zinc Slider



26.4 Auto Spring-lock Zinc Slider (3 components)



26.5 Auto-lock Zinc Slider (5 components)

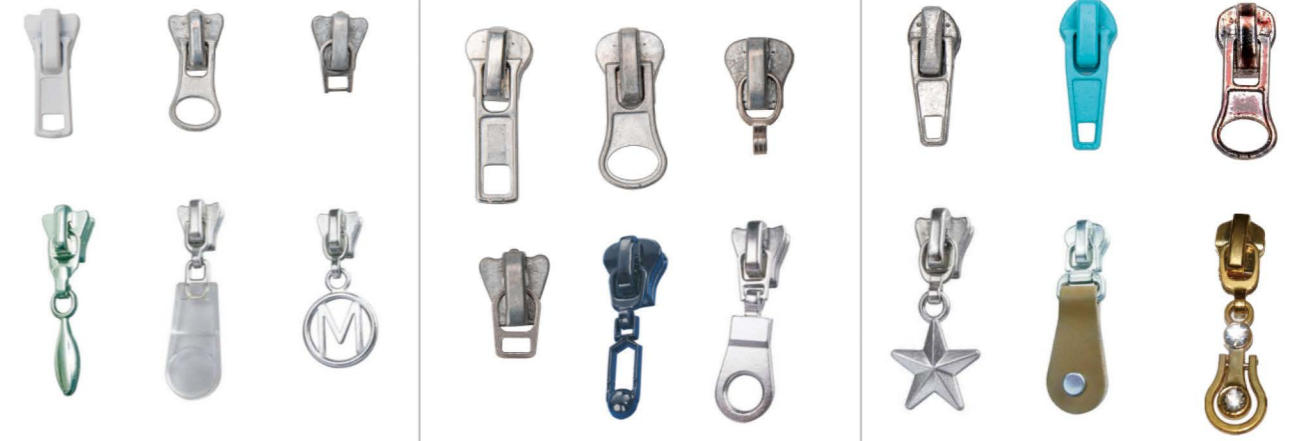
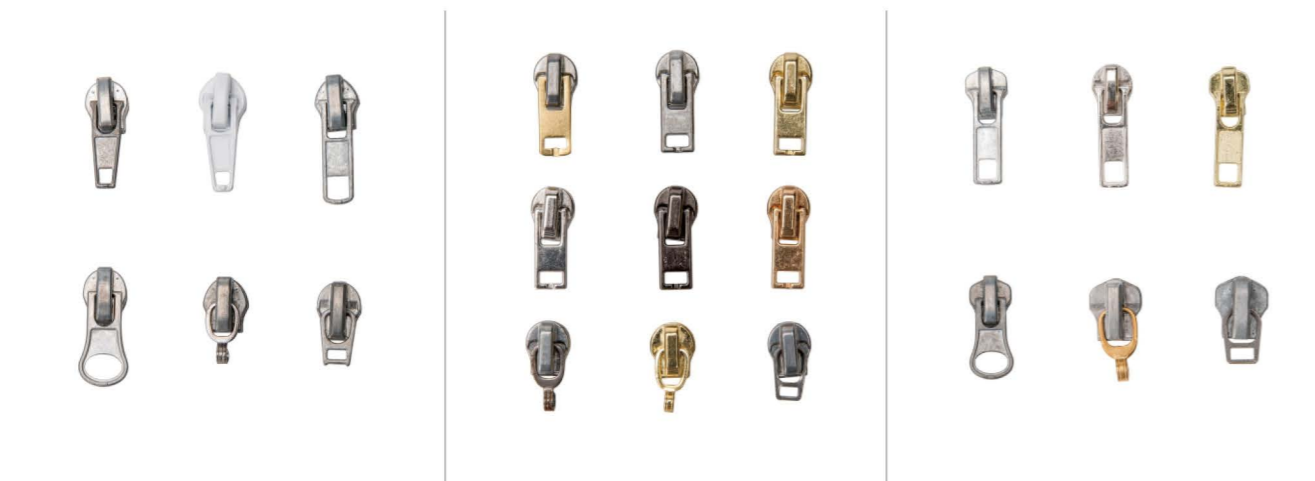

26.6 Invisible Zinc Slider



26.7 Italy Type Zinc Slider

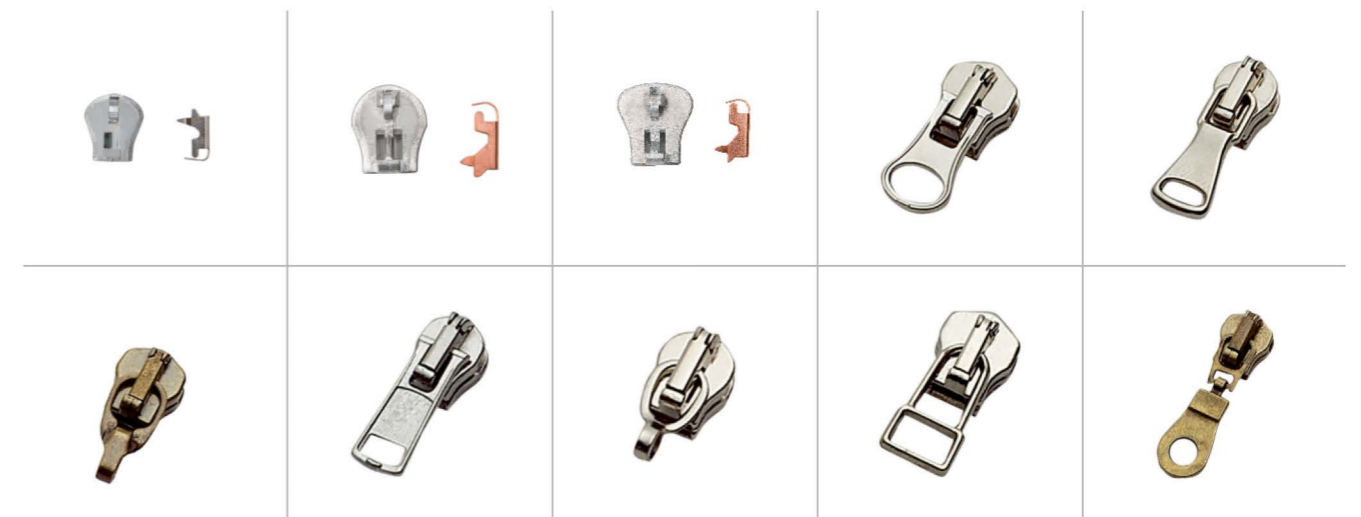

26.8 Other Type Zinc Slider



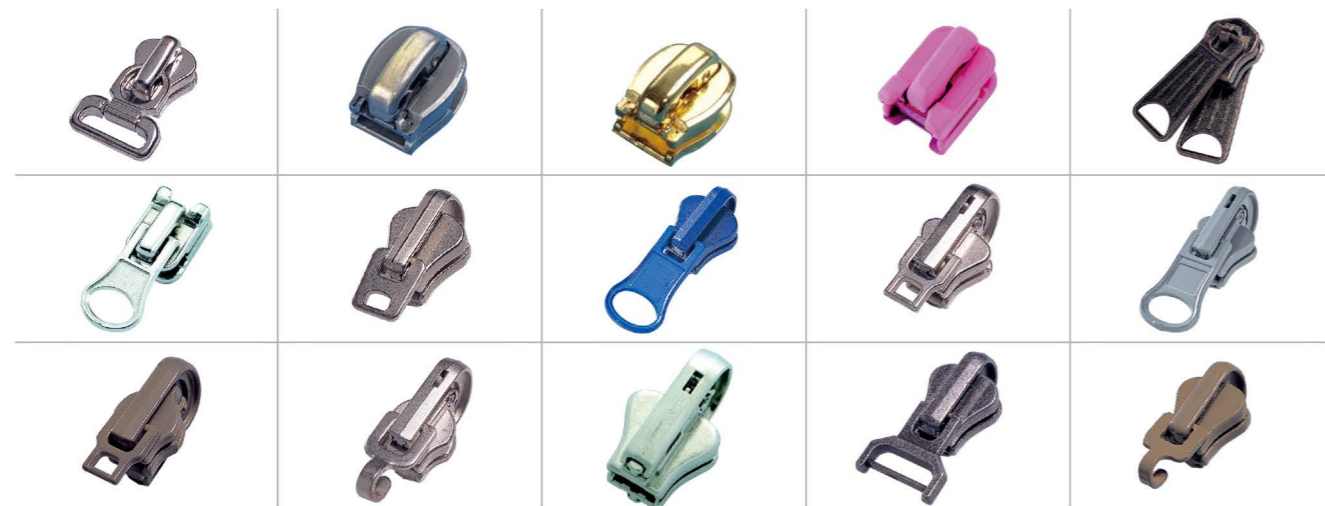

26.9 Zinc Pin Box



27 Zipper Tape



Nylon Zipper Tape

Invisible Zipper Tape

Metal Zipper Tape

Plastic Zipper Tape

28 Long-chain Zipper











29 Finished Zipper

			
Nylon Finished Zipper	Invisible Finished Zipper	Metal Finished Zipper	Plastic Finished Zipper
			
Embossing Finished Zipper	Diamond Finished Zipper	Waterproof Finished Zipper	Fire Retardant Finished Zipper
			
(Stainless Steel) Metal Finished Zipper	(Aluminum) Metal Finished Zipper	Metallic Plastic Zipper	Plastic Magnetic Zipper

30 Button Part

			
			

		
12.9mm	12.9mm	12.9mm
		
15.9mm	15.9mm	15.9mm
		
18.9mm	18.9mm	18.9mm
Stainless Steel Button Shell (without hole)		
		
Button Shell for Double Feet		
		
Double Feet		
		
	12.9mm	12.9mm
		
	15.9mm	15.9mm
		
	18.9mm	18.9mm
	Stainless Steel Button Shell (with hole)	Stainless Steel Flexible Button Part (with hole)

		
12.9mm		
		
15.9mm		
		
18.9mm		
Stainless Steel Fixing Button Part (with white plastic core)	Stainless Steel Button Nail	Stainless Steel Button Foot

31 Bag Accessories

S/N	Sample	Specs	S/N	Sample	Specs	S/N	Sample	Specs
01		6.0X20.5X27.2	13		3.0x10x14.3	25		3.5x12.5x17
02		6.0X22.2X27.2	14		2.8x9.5x13.5	26		3.0x10x14
03		5.0X16X23.6	15		2.3x8x12	27		3.0x11x14
04		5.0X16X23.6	16		1.6x7.5x11	28		3.0x11x14
05		4.5X15X20.5	17		4.4x17x20	29		3.0x10x14
06		4.5X15X20.5	18		4.4x17x20	30		2.8x9.5x13.5
07		4.0X12.5X18.5	19		4.4x17x20	31		2.6x8.5x11.8
08		3.8X13X18.7	20		4.5x14x21	32		2.5x8.5x11.7
09		3.8X12.5X18	21		4.0x14x20	33		2.2x8x10
10		3.8X13X16.3	22		3.5x13x17	34		2.4x8.5x11.8
11		3.4X11X16.3	23		3.5x12x17	35		2.0x7x10.5
12		3.4X11X16.3	24		3.5x11.5x16	36		6.8x30x40

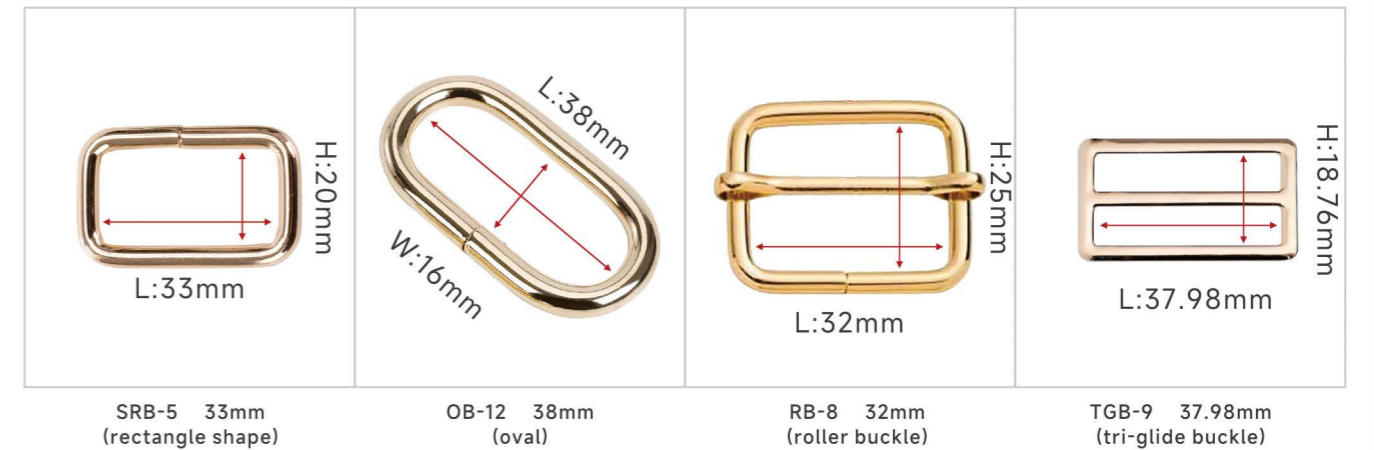
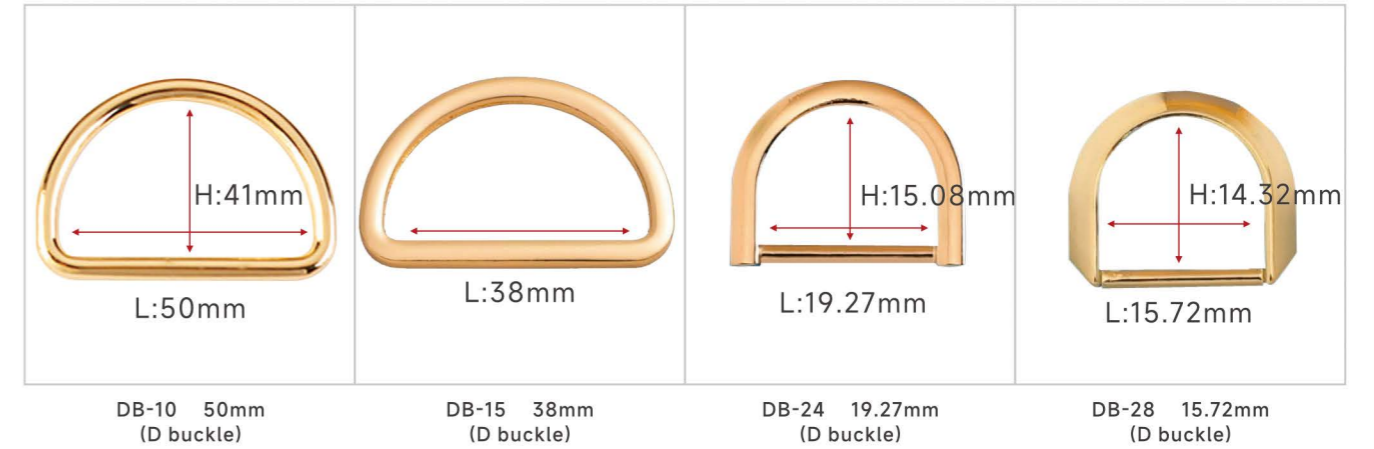
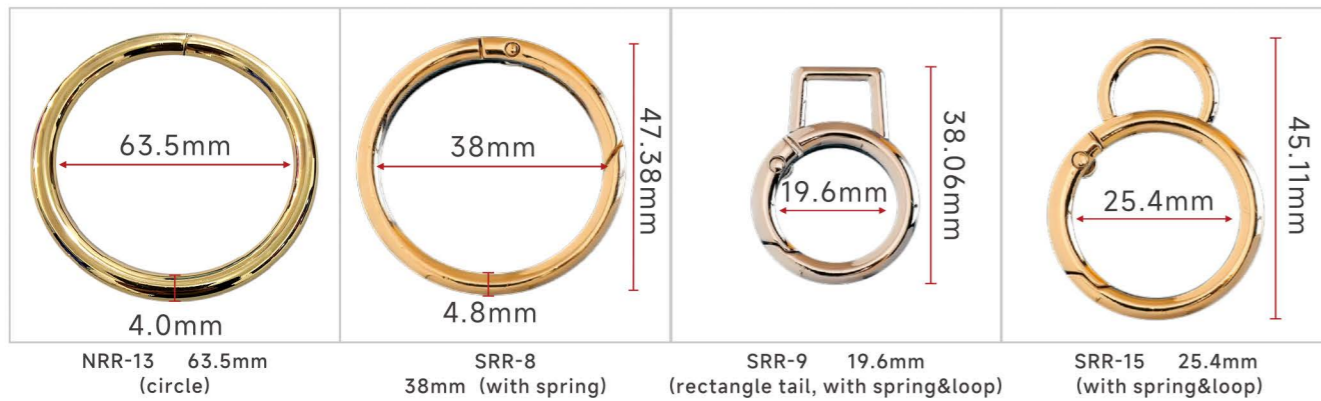
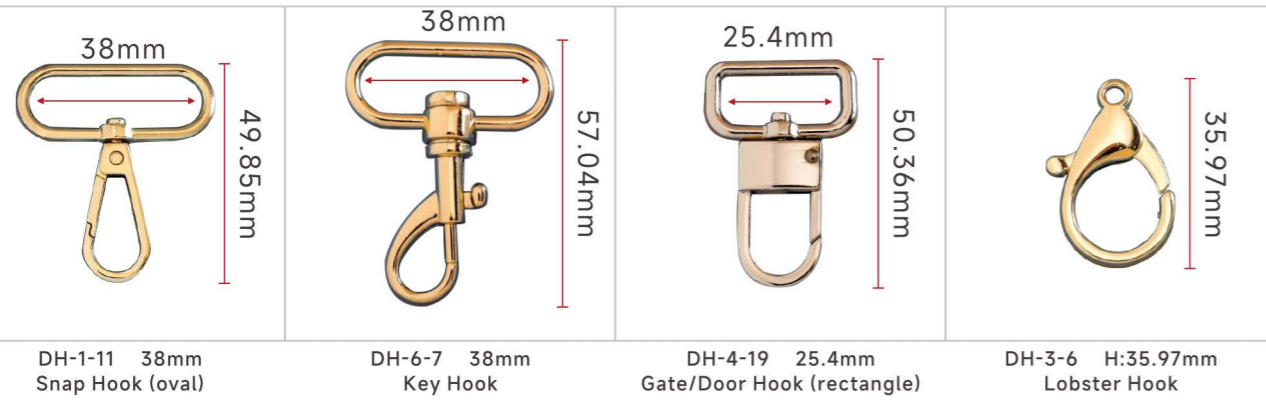

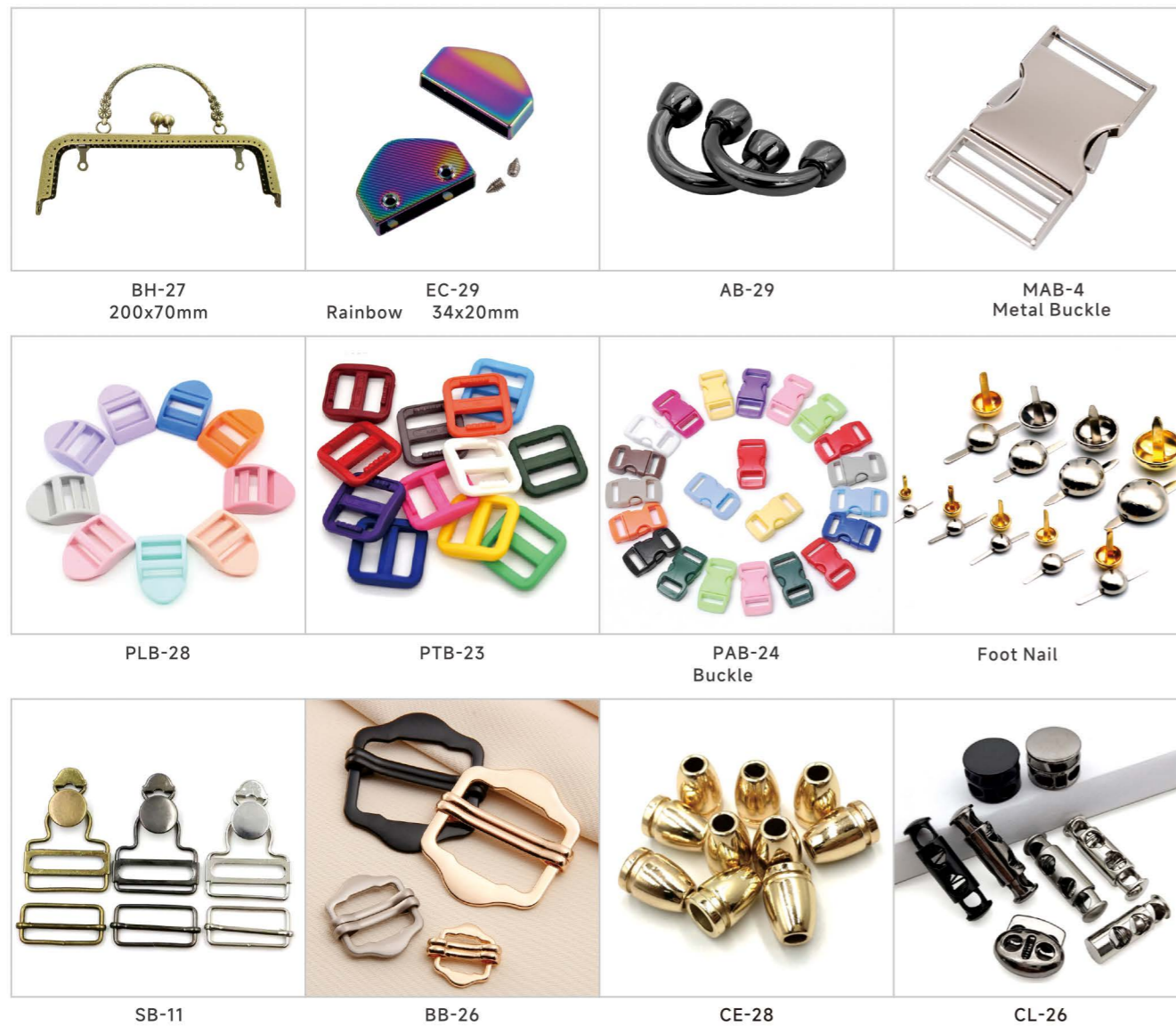

32 Velcro (hook & loop)



33 Chemical for Plating



Besides above chemicals, we have other chemicals for your choosing.

